

**TYRONE TOWNSHIP
REGULAR BOARD MEETING AGENDA
JUNE 18, 2019 - 7:00 P.M.
(810) 629-8631**

CALL TO ORDER – PLEDGE OF ALLEGIANCE – 7:00 P.M.

ROLL CALL

APPROVAL OF AGENDA – OR CHANGES

APPROVAL OF CONSENT AGENDA

Regular Board Meeting Minutes – June 4, 2019
Treasurer's Report
Clerk's Warrants and Bills

COMMUNICATIONS

1. Planning Commission Meeting Synopsis- June 11, 2019
2. Planning Commission Approved Meeting Minutes- April 17, 2019
3. Planning Commission Approved Meeting Minutes- May 14, 2019

PUBLIC REMARKS

UNFINISHED BUSINESS

NEW BUSINESS

1. ZBA appointment.
2. Resolution to proceed with the Laurel Springs Waste Removal Project.
3. Resolution to schedule the first public hearing and issue notices for the Laurel Springs Waste Removal Project.
4. Resolution to adopt the proposed Private Infrastructure Special Assessments Policy.
5. Resolution to adopt the proposed Purchasing of Goods and Services Policy.
6. 2019-2020 Budget Amendment.
7. Request to amend the Cider Mill Crossings consent judgment.

MISCELLANEOUS BUSINESS

PUBLIC REMARKS

ADJOURNMENT

* * * * *

Supervisor Mike Cunningham Clerk Marcella Husted

Please note: The Public Remarks section appears twice on the agenda - once after Communications and once before Adjournment. Anyone wishing to address the Township Board may do so at these times. The Tyrone Township Board of Trustees has established a policy limiting the time a person may address the Township Board at a regular or at a special meeting during the Public Remarks section of the agenda to three minutes. The Board reserves the right to place an issue under the New Business section of the agenda if additional discussion is warranted or to respond later either verbally or in writing through an appropriately appointed Township Official. - Individuals with disabilities requiring auxiliary aids or services should contact the Tyrone Township Clerk at (810) 629-8631 at least seven days prior to the meeting.

CONSENT AGENDA

**TYRONE TOWNSHIP
PUBLIC HEARING & REGULAR BOARD MEETING
APPROVED MINUTES – JUNE 4, 2019**

CALL TO ORDER

Supervisor Cunningham called the meeting of the Tyrone Township Board to order with the Pledge of Allegiance on June 4, 2019 at 7:00 p.m. at the Tyrone Township Hall.

ROLL CALL

Present: Supervisor Mike Cunningham, Treasurer Jennifer Eden, Clerk Marcella Husted, Trustees Al Pool, David Walker, Soren Pedersen, and Chuck Schultz.

PUBLIC HEARING

Supervisor Cunningham opened the public hearing at 7:00 pm. The purpose of the public hearing was to explain and answer question pertaining to the Roll and to hear objections to the Roll for the Irish Hills Road Improvement Project. Resident David Haver (Tipperary Trail) voiced his objections to the project. No other objections were heard and no letters of objection were received. The Supervisor closed the public hearing and reopened the regular meeting at 7:15 p.m.

APPROVAL OF AGENDA – OR CHANGES

Trustee Walker moved to approve the agenda as presented. (Trustee Schultz seconded.) The motion carried; all ayes.

APPROVAL OF CONSENT AGENDA

**Regular Board Meeting Minutes – May 21, 2019
Clerk's Warrants and Bills**

Trustee Walker moved to approve the consent agenda as presented. (Trustee Schultz seconded.) The motion carried; all ayes.

COMMUNICATIONS

1. Fire Run Collection Report

Trustee Walker moved to receive and place on file Communication #1 as presented. (Trustee Pool seconded.) The motion carried; all ayes.

PUBLIC REMARKS

None.

UNFINISHED BUSINESS

None.

NEW BUSINESS

1. Selection of contractor for the Irish Hills Road Improvement Project.

Trustee Walker moved to award the Irish Hills Road Improvement Contract to Allied Construction for their bid of \$687,786.00. (Trustee Schultz seconded.) The motion carried; all ayes.

**TYRONE TOWNSHIP
PUBLIC HEARING & REGULAR BOARD MEETING
APPROVED MINUTES – JUNE 4, 2019 – PAGE 2**

2. Resolution to confirm the special assessment roll for the Irish Hills Road Improvement Project.

RESOLUTION #190601
TYRONE TOWNSHIP, LIVINGSTON COUNTY

RESOLUTION #6 – IRISH HILLS SUBDIVISION ROAD IMPROVEMENT PROJECT (2019)

RESOLUTION CONFIRMING SPECIAL ASSESSMENT ROLL

WHEREAS, the Township Board has taken the necessary actions under Act No. 188, Public Acts of Michigan, 1954, as amended (“Act 188”) to proceed with the Irish Hills Subdivision road improvements, as described in Exhibit A (the “Project”), and for the establishment of the Tyrone Township Irish Hills Subdivision Road Improvement Project (2019) Special Assessment District (the “Special Assessment District”);

WHEREAS, the Township Board has determined that it is necessary to cause special assessments to be levied against the lands especially benefited by the Project to pay the Township’s obligations on the Project;

WHEREAS, the Township Board has directed the Township Supervisor to prepare a proposed special assessment roll (the “Special Assessment Roll”) against the lands especially benefited by the Project;

WHEREAS, the Township Supervisor has prepared the Special Assessment Roll and has filed the Special Assessment Roll with the Township Clerk;

WHEREAS, the Township Board has scheduled a public hearing on the proposed Special Assessment Roll and notice of the hearing has been properly provided;

WHEREAS, the Township Board conducted the public hearing on the proposed Special Assessment Roll on June 4, 2019.

NOW, THEREFORE, BE IT RESOLVED THAT:

1. Roll Confirmed. In accordance with Act No. 188 and the laws of the State of Michigan, the Township Board hereby confirms the special assessment roll for the Tyrone Township Irish Hills Subdivision Road Improvement Project (2019) (the “Roll”).
2. Future Installments - Principal. The Township Board determines that each special assessment may be paid in twenty (20) annual installments. The first installment shall be due on December 1, 2019. Each subsequent installment shall be due at intervals twelve (12) months from the due date of the first installment.

**TYRONE TOWNSHIP
PUBLIC HEARING & REGULAR BOARD MEETING
APPROVED MINUTES – JUNE 4, 2019 – PAGE 3**

3. Future Installments - Interest. All unpaid installments shall bear interest, payable annually on each installment due date, at a rate equal to one percent (1%) above the average interest rate on the Township bonds sold to finance the Project. Interest on such unpaid installments shall accrue from July 1, 2019.

4. Warrant. The Township Clerk is hereby directed to attach a warrant (in the form of Exhibit B to this resolution) to the Roll and to deliver such warrant and the Roll to the Township Treasurer, who shall thereupon collect the special assessments in accordance with the terms of this resolution, the Clerk's warrant and the statutes of the State of Michigan.

5. Inconsistent Prior Resolutions. All previously adopted resolutions that are in conflict with this resolution are repealed to the extent of such conflict.

RESOLVED BY: Trustee Schultz
SUPPORTED BY: Trustee Walker

VOTE: Pedersen, yes; Cunningham, yes; Pool, yes; Schultz, yes; Walker, yes; Eden, yes; Husted, yes.

ADOPTION DATE: June 4, 2019

CERTIFICATION OF THE CLERK

The undersigned, being the duly qualified and acting Clerk of Tyrone Township, Livingston County, Michigan, hereby certifies that (1) the foregoing is a true and complete copy of a resolution adopted by the Township Board at a regular meeting, held on June 4, 2019, at which meeting a quorum was present and remained throughout, (2) the original thereof is on file in the records in my office, (3) the meeting was conducted, and public notice thereof was given, pursuant to and in full compliance with the Open Meetings Act (Act No. 267, Public Acts of Michigan, 1976, as amended) and (4) minutes of such meeting were kept and will be or have been made available as required thereby.



Marcella Husted
Township Clerk

Exhibit A
Description of the Project

The Project will consist of making certain road improvements to the following roads in and around the Irish Hills Subdivision: Donegal Court, Dublin Drive, Tipperary Trail and Wicklow Hill Court. A detailed description of the proposed road improvement is on file with the Township Clerk.

**TYRONE TOWNSHIP
PUBLIC HEARING & REGULAR BOARD MEETING
APPROVED MINUTES – JUNE 4, 2019 – PAGE 4**

Exhibit B
Warrant

WARRANT

TO: Treasurer
Tyrone Township
Livingston County, Michigan

I certify that attached to this Warrant is a true copy of the special assessment roll for the Tyrone Township Irish Hills Subdivision Road Improvement Project (2019) confirmed by the Township Board on June 4, 2019 (the “Confirming Resolution”). You are hereby directed to proceed to collect the amounts due on such roll in accordance with this Warrant, the Confirming Resolution and the statutes of the State of Michigan.

Marcella Husted
Tyrone Township Clerk

3. Bond authorizing resolution for the Irish Hills Road Improvement Project.

RESOLUTION #190602
TYRONE TOWNSHIP, LIVINGSTON COUNTY

RESOLUTION #7 – IRISH HILLS SUBDIVISION ROAD IMPROVEMENT PROJECT (2019)

BOND AUTHORIZING RESOLUTION

WHEREAS, the necessary proceedings have been taken by the Township Board to make certain road improvements in the special assessment district for the Tyrone Township Irish Hills Subdivision Road Improvement Project (2019) (the “District”) and such road improvements are described in Exhibit A attached hereto (the “Project”);

WHEREAS, such proceedings provide for the payment of the cost of the Project by special assessments levied against the benefited lands in the District (the “Assessments”), and a special assessment roll has been confirmed by the Township Board for the District; and

WHEREAS, it has been determined by the Township Board to issue bonds in the amount herein authorized in anticipation of the collection of the Assessments and to allocate the Assessments to pay the principal of and interest on the Bonds (as defined below);

**TYRONE TOWNSHIP
PUBLIC HEARING & REGULAR BOARD MEETING
APPROVED MINUTES – JUNE 4, 2019 – PAGE 5**

NOW, THEREFORE, BE IT RESOLVED THAT:

1. The Project. The construction of the Project and the period of usefulness of the Project, and the Township’s proceedings with respect to the Assessments for the Project, are hereby approved and confirmed. It is hereby determined that each respective Assessment will be proportionate to the benefits that each respective parcel of property will derive from the Project.

2. Bond Details. The Township shall borrow not to exceed \$870,000 and issue its Bonds therefor (the “Bonds”) for the purpose of paying the total cost of the Project. The Bonds shall be designated as “Tyrone Township Irish Hills Subdivision Road Improvement Project Special Assessment Bonds, Series 2019 (Limited Tax General Obligation)” and shall be dated such date as the Township Supervisor, the Township Clerk or the Township Treasurer (together, the Authorized Officers and each an “Authorized Officer”) shall provide prior to the sale of the Bonds, and shall bear interest from that date. The Bonds shall be fully registered Bonds, both as to principal and interest, in any denomination which is \$1,000, or any integral multiple thereof up to a single maturity, or as otherwise authorized by an Authorized Officer prior to the sale of the Bonds, numbered from 1 upwards, and shall mature on July 1 of each year as set forth in the following maturity schedule, or alternatively on such other dates and in such other amounts as may be determined by an Authorized Officer prior to the sale of the Bonds.

Year	Amount
2020	\$10,000
2021	45,000
2022	45,000
2023	45,000
2024	45,000
2025	45,000
2026	45,000
2027	45,000
2028	45,000
2029	45,000
2030	45,000
2031	45,000
2032	45,000
2033	45,000
2034	45,000
2035	45,000
2036	45,000
2037	45,000
2038	40,000
2039	55,000

The Bonds shall be in substantially the form attached as Exhibit B with such changes, additions or deletions as are not inconsistent with this Resolution.

**TYRONE TOWNSHIP
PUBLIC HEARING & REGULAR BOARD MEETING
APPROVED MINUTES – JUNE 4, 2019 – PAGE 6**

3. Interest Payment and Date of Record. The Bonds shall bear interest payable on January 1 and July 1 of each year, beginning January 1, 2020, or such other date or dates as may be determined by an Authorized Officer prior to the sale of the Bonds. Interest shall be paid by check or draft mailed by first class mail to the registered owner of each Bond as of the applicable date of record; provided, however, that an Authorized Officer may agree with the Bond Registrar on a different method of payment. If interest is paid differently, the Bond form attached as Exhibit B shall be changed accordingly. The date of record shall be the fifteenth day of the month immediately preceding the month in which such interest is payable.

4. Optional Redemption. The Bonds shall be subject to redemption at the option of the Township prior to maturity to the extent and as determined by an Authorized Officer prior to the sale of the Bonds, provided that no redemption premium shall be paid in connection with such optional redemptions.

5. Provisions for the Sale and Award of the Bonds. The Township shall sell the Bonds in conformance with 1954 Michigan Public Act 188, as amended (“Act 188”), 2001 Michigan Public Act 34, as amended (“Act 34”), and the laws of the State of Michigan, and the rules and regulations of the Michigan Department of Treasury. Each Authorized Officer is authorized and directed, after consultation with the Township’s Financial Advisor and Bond Counsel (both as defined herein), to approve the specific interest rates to be borne by the Bonds, the purchase price of the Bonds, and other terms and conditions relating to the Bonds and the sale thereof, provided that the interest rates, purchase price, and other terms and conditions comply with the following parameters:

- (a) The interest rate for any maturity or maturities of the Bonds shall not exceed six percent (6%) per annum;
- (b) The true interest cost for the Bonds, as computed by the Township’s Financial Advisor, shall not exceed five percent (5%) per annum;
- (c) The purchase price for the Bonds, not including underwriter’s or purchaser’s discount, shall not be less than ninety-nine and one-half percent (99.5%) and shall not be greater than one hundred and two percent (102%) of the principal amount of the Bonds; and
- (d) The underwriter’s or purchaser’s discount in connection with the sale of the Bonds shall not exceed five percent (5%) of the principal amount of the Bonds.

6. Method of Sale – Competitive Sale. The Township shall sell the Bonds via competitive sale. Sealed bids for the purchase of the Bonds shall be accepted up to a time to later be determined by an Authorized Officer. The Official Notice of Sale for the Bonds shall be published once in accordance with law in The Bond Buyer, in a form approved by an Authorized Officer. Any Authorized Officer may cause the Official Notice of Sale to be published in additional publications, as such Authorized Officer deems appropriate. Each Authorized Officer is authorized to award the sale of the Bonds to the bidder whose bid produces the lowest true interest cost to the Township, as determined by the Township’s Financial Advisor, provided that such winning bid complies with the parameters set forth in this Resolution.

**TYRONE TOWNSHIP
PUBLIC HEARING & REGULAR BOARD MEETING
APPROVED MINUTES – JUNE 4, 2019 – PAGE 7**

7. Option for Private Placement. As an alternative to the sale of the Bonds via competitive sale as described in the preceding paragraph, an Authorized Officer, after consultation with the Township's Financial Advisor and Bond Counsel, is hereby authorized to determine that the Bonds shall be sold via private placement pursuant to Section 309(1) of Act 34. The Township hereby determines that such sale will provide additional flexibility in the structure, terms and timing of the sale and delivery of the Bonds. In the event of a private placement, each Authorized Officer is authorized to award the sale of the Bonds to a purchaser, provided that the terms of such sale are within the parameters set forth in this Resolution.

8. Bond Registrar, Transfer and Paying Agent. The Bonds shall be registrable upon the books maintained by a financial institution to be designated by an Authorized Officer prior to the sale of the Bonds, and such financial institution shall serve as bond registrar, transfer agent and authenticating agent for the Bonds (the "Bond Registrar").

9. Transfer or Exchange of Bonds. Any Bond shall be transferable on the bond register maintained by the Bond Registrar with respect to the Bonds at any time upon the surrender of the Bond together with an assignment executed by the registered owner or his or her duly authorized attorney in form satisfactory to the Bond Registrar. Upon receipt of a properly assigned Bond, the Bond Registrar shall authenticate and deliver a new Bond or Bonds in equal aggregate principal amount and like interest rate and maturity to the designated transferee or transferees.

Bonds may likewise be exchanged at any time for one or more other Bonds with the same interest rate and maturity in authorized denominations aggregating the same principal amount as the Bond or Bonds being exchanged. Such exchange shall be effected by surrender of the Bond to be exchanged to the Bond Registrar with written instructions signed by the registered owner of the Bond or his or her attorney in form satisfactory to the Bond Registrar. Upon receipt of a Bond with proper written instructions, the Bond Registrar shall authenticate and deliver a new Bond or Bonds to the registered owner of the surrendered Bond or his or her properly designated transferee or transferees or attorney.

The Bond Registrar is not required to honor any transfer or exchange of Bonds during the 15 days preceding an interest payment date. Any service charge made by the Bond Registrar for any such registration, transfer or exchange shall be paid for by the Township. The Bond Registrar may, however, require payment by a bondholder of a sum sufficient to cover any tax or other governmental charge payable in connection with any such registration, transfer or exchange.

10. Execution and Delivery. The Township Supervisor and the Township Clerk are authorized and directed to execute the Bonds for and on behalf of the Township by manually executing the Bonds or by having facsimiles of their signatures affixed to the Bonds. Upon execution of the Bonds, they shall be delivered to the Township Treasurer, or an agent thereof, who is hereby authorized and directed to deliver the Bonds to the purchaser upon receipt in full of the purchase price for the Bonds.

**TYRONE TOWNSHIP
PUBLIC HEARING & REGULAR BOARD MEETING
APPROVED MINUTES – JUNE 4, 2019 – PAGE 8**

11. Full Faith and Credit Pledged. The Bonds are being issued in anticipation of the collection of future due installments of the Assessments. The Assessments and interest and investment income thereon are projected to be sufficient to pay the principal of and interest on the Bonds when due and such funds are pledged as security for the payment of the principal of and interest on the Bonds. Additionally, the Township hereby irrevocably pledges its limited tax full faith and credit as additional security for the payment of the principal of and interest on the Bonds. Pursuant to such pledge, should Assessment collections be insufficient to pay the principal of and interest on the Bonds when due, the Township shall pay the principal of and interest on the Bonds as a first budget obligation from its general funds, including the collection of any ad valorem taxes which the Township is authorized to levy, but any such levy shall be subject to applicable constitutional, charter and statutory tax rate limitations.

12. Bond Payment Fund. The Township shall establish a separate depository account to be designated “Irish Hills Subdivision Road Improvement Project Special Assessment Bonds, Series 2019, Bond Payment Fund” (the “Bond Payment Fund”). All accrued interest and premium, if any, received from the purchaser of the Bonds, together with any portion of the Bond proceeds designated by an Authorized Officer to fund a capitalized interest reserve, and all amounts (including principal, interest and penalties) at any time received in payment of the Assessments shall be deposited in the Bond Payment Fund. Moneys in the Bond Payment Fund shall be used, except as described above, solely to pay principal of and premium, if any, and interest on the Bonds.

Moneys in the Bond Payment Fund may be continuously invested and reinvested in any legal investment for Township funds, which shall mature, or which shall be subject to redemption by the holder thereof not later than, the dates when moneys in the Bond Payment Fund will be required to pay the principal of and interest on the Bonds. Obligations purchased as an investment of moneys of the Bond Payment Fund shall be deemed at all times to be a part of such fund, and the interest accruing thereon and any profit realized from such investment shall be credited to such fund.

13. Improvement Fund. Except for amounts required by this resolution to be deposited in the Bond Payment Fund, the proceeds from the sale of the Bonds shall be deposited in a separate depository account to be designated “Irish Hills Subdivision Road Improvement Project Special Assessment Bonds, Series 2019, Improvement Fund” (the “Improvement Fund”).

Moneys at any time in the Improvement Fund shall be used solely to pay costs of the Project except that upon payment (or provision for payment) in full of the costs of the Project, any excess moneys remaining in the Improvement Fund shall be transferred to the Bond Payment Fund (if any Bonds are outstanding) or applied as required by law or the ordinances of the Township and shall be used for “essential government functions” as that term is used in Section 141(c)(2) of the Internal Revenue Code of 1986, as amended (the “Code”).

**TYRONE TOWNSHIP
PUBLIC HEARING & REGULAR BOARD MEETING
APPROVED MINUTES – JUNE 4, 2019 – PAGE 9**

Moneys in the Improvement Fund may be continuously invested and reinvested in any legal investment for Township funds, which shall mature, or which shall be subject to redemption by the holder thereof not later than, the estimated dates when moneys in the Improvement Fund will be required to pay costs of the Project. Obligations purchased as an investment of moneys of the Improvement Fund shall be deemed at all times to be a part of such fund, and the interest accruing thereon and any profit realized from such investment shall be credited to such fund.

14. Mutilated, Lost, Stolen or Destroyed Bonds. In the event any Bond is mutilated, lost, stolen or destroyed, the Township Supervisor and the Township Clerk may, on behalf of the Township, execute and deliver, or order the Bond Registrar to authenticate and deliver, a new Bond having a number not then outstanding, of like date, maturity, interest rate and denomination as that mutilated, lost, stolen or destroyed Bond.

In the case of a mutilated Bond, a replacement Bond shall not be delivered unless and until such mutilated Bond is surrendered to the Bond Registrar. In the case of a lost, stolen or destroyed Bond a replacement Bond shall not be delivered unless and until the Township and the Bond Registrar shall have received such proof of ownership and loss and indemnity as they determine to be sufficient, which shall consist at least of (i) a lost instrument bond for principal and interest remaining unpaid on the lost, stolen or destroyed Bond; (ii) an affidavit of the registered owner (or his or her attorney) setting forth ownership of the Bond lost, stolen or destroyed and the circumstances under which it was lost, stolen or destroyed; (iii) the agreement of the owner of the Bond (or his or her attorney) to fully indemnify the Township and the Bond Registrar against loss due to the lost, stolen or destroyed Bond and the issuance of any replacement Bond in connection therewith; and (iv) the agreement of the owner of the Bond (or his or her attorney) to pay all expenses of the Township and the Bond Registrar in connection with the replacement, including the transfer and exchange costs which otherwise would be paid by the Township.

15. Arbitrage and Tax Covenants. Notwithstanding any other provision of this Resolution, the Township covenants that it will not at any time or times:

(a) Permit any proceeds of the Bonds or any other funds of the Township or under its control to be used directly or indirectly (i) to acquire any securities or obligations, the acquisition of which would cause any Bond to be an “arbitrage bond” as defined in Section 148 of the Code, or (ii) in a manner which would result in the exclusion of any Bond from the treatment afforded by Section 103(a) of the Code by reason of the classification of any Bond as a “private activity bond” within the meaning of Section 141(a) of the Code or as an obligation guaranteed by the United States of America within the meaning of Section 149(b) of the Code; or

(b) Take any action, or fail to take any action (including failure to file any required information or other returns with the United States Internal Revenue Service or to rebate amounts to the United States, if required, at or before the time or times required), within its

**TYRONE TOWNSHIP
PUBLIC HEARING & REGULAR BOARD MEETING
APPROVED MINUTES – JUNE 4, 2019 – PAGE 10**

control which action or failure to act would (i) cause the interest on the Bonds to be includable in gross income for federal income tax purposes, cause the interest on the Bonds to be includable in computing any alternative minimum tax (other than the alternative minimum tax applicable to interest on all tax exempt obligations generally) or cause the proceeds of the Bonds to be used directly or indirectly by an organization described in Section 501(c)(3) of the Code or (ii) adversely affect the exemption of the Bonds and the interest thereon from State of Michigan income taxation.

16. Qualification of Bonds. The Township Board hereby designates the Bonds as “qualified tax exempt obligations” for the purpose of deduction of interest expense by financial institutions under the provisions of Section 265(b) of the Code, unless otherwise certified by an Authorized

Officer prior to the sale of the Bonds. Each Authorized Officer is authorized and directed to make such changes to the form of the Bonds set forth in Exhibit B, as may in such officer’s discretion, be necessary to reflect any withdrawal of the designation made hereunder.

17. Defeasance. If at any time,

(a) the whole amount of the principal of and premium, if any, and interest due and payable upon all outstanding Bonds shall be paid, or

(b) if sufficient moneys, or Government Obligations not callable prior to maturity, the principal of and interest on which, when due and payable will provide such sufficient moneys without reinvestment, shall be deposited with and held by a trustee for the purpose of paying principal of and premium, if any, and interest due and payable upon all outstanding Bonds, and if all outstanding Bonds to be redeemed prior to maturity shall have been duly called for redemption or irrevocable instructions to call such Bonds for redemption shall have been given to such trustee,

then the right, title and interest of the holders of the Bonds shall thereupon cease, terminate and become void and the Township shall be released from the obligations of this resolution and any moneys or other funds held pursuant to this resolution for the purpose of paying principal of and premium, if any, and interest on the Bonds then outstanding (other than the aforementioned funds on deposit with the trustee for redemption of the outstanding Bonds) shall be released from the conditions of this resolution and paid over to the Township and considered excess proceeds of the Bonds. All moneys and Government Obligations held by such trustee pursuant to this Section shall be held in trust and applied to the payment, when due, of the obligations payable therewith as provided hereinabove. As used herein the term “Government Obligations” means direct obligations of, or obligations the principal of and interest on which are unconditionally guaranteed by, the United States of America.

The trustee or escrow agent referred to in the paragraph set forth above shall (i) be a bank or trust company permitted by law to offer and offering the required services, (ii) be appointed by an Authorized Officer and (iii) at the time of its appointment and so long as it is serving as

**TYRONE TOWNSHIP
PUBLIC HEARING & REGULAR BOARD MEETING
APPROVED MINUTES – JUNE 4, 2019 – PAGE 11**

such, have at least \$25,000,000 of capital and unimpaired surplus. The same bank or trust company may serve as trustee or escrow agent and as Bond Registrar so long as it is otherwise eligible to serve in each such capacity.

18. Additional Bonds. Additional bonds of equal standing with the Bonds may be issued in connection with the Project. Nothing in this Resolution shall prevent the issuance by the Township of bonds to finance other projects for the Township.

19. Continuing Disclosure. Based on consultations with the Financial Advisor and Bond Counsel, each Authorized Officer is hereby authorized to execute a Continuing Disclosure Undertaking with respect to the Bonds if such undertaking is necessary for the sale of the Bonds. The Bonds are hereby made subject to such Continuing Disclosure Undertaking, if any, and the Township agrees to abide by the provisions of any such Continuing Disclosure Undertaking so long as any of the Bonds are outstanding.

20. Retention of Bond Counsel. The firm of Dykema Gossett PLLC, Lansing, Michigan, is hereby retained to serve as bond counsel (“Bond Counsel”) for the Township in connection with the issuance, sale and delivery of the Bonds.

21. Retention of Financial Advisor. PFM Financial Advisors, LLC, Ann Arbor, Michigan, is hereby retained to serve as financial advisor to the Township in connection with the issuance, sale and delivery of the Bonds (the “Financial Advisor”).

22. Conflicting Resolutions. All resolutions and parts of resolutions in conflict with the foregoing are hereby rescinded.

23. Effective Date. This Resolution shall become effective immediately upon its adoption and shall be recorded in the minutes of the Township as soon as is practicable after its passage.

RESOLVED BY: Trustee Schultz
SUPPORTED BY: Trustee Pool

VOTE: Walker, yes; Schultz, yes; Pool, yes; Cunningham, yes; Eden, yes; Pedersen, yes; Husted, yes.

ADOPTION DATE: June 4, 2019

CERTIFICATION OF THE CLERK

The undersigned, being the duly qualified and acting Clerk of Tyrone Township, Livingston County, Michigan, hereby certifies that (1) the foregoing is a true and complete copy of a resolution adopted by the Township Board at a regular meeting, held on June 4, 2019, at which meeting a quorum was present and remained throughout, (2) the original thereof is on file in the records in my office, (3) the meeting was conducted, and public notice thereof was given, pursuant to and in full compliance with the Open Meetings Act (Act No. 267, Public Acts of Michigan, 1976, as amended) and (4) minutes of such meeting were kept and will be or have been made available as required thereby.

**TYRONE TOWNSHIP
PUBLIC HEARING & REGULAR BOARD MEETING
APPROVED MINUTES – JUNE 4, 2019 – PAGE 12**

Marcella Husted

Marcella Husted
Township Clerk

Exhibit A
Description of the Project

The Project will consist of making certain road improvements to the following roads in and around the Irish Hills Subdivision: Donegal Court, Dublin Drive, Tipperary Trail and Wicklow Hill Court. A detailed description of the proposed road improvement is on file with the Township Clerk.

Exhibit B
Form of Bond

Unless this certificate is presented by an authorized representative of The Depository Trust Company, a New York corporation (“DTC”), to the Township or its agent for registration of transfer, exchange, or payment and any certificate issued is registered in the name of Cede & Co. or in such other name as is requested by an authorized representative of DTC (and any payment is made to Cede & Co. or to such other entity as is requested by an authorized representative of DTC), ANY TRANSFER, PLEDGE, OR OTHER USE HEREOF FOR VALUE OR OTHERWISE BY OR TO ANY PERSON IS WRONGFUL inasmuch as the registered owner hereof, Cede & Co., has an interest herein.

UNITED STATES OF AMERICA
STATE OF MICHIGAN
COUNTY OF LIVINGSTON

Tyrone Township Irish Hills Subdivision Road Improvement Project
Special Assessment Bonds, Series 2019 (Limited Tax General Obligation)

Date of Issuance Rate Maturity Date CUSIP
_____, 2019 ____% July 1, 20__

Registered Owner: Cede & Co.
Principal Amount: *****\$_____*****

FOR VALUE RECEIVED, Tyrone Township (the “Township”), Livingston County, State of Michigan, hereby acknowledges itself indebted and promises to pay on the Maturity Date specified above, to the Registered Owner specified above, or registered assigns, the Principal Amount shown above, upon presentation and surrender of this Bond at the principal office of

**TYRONE TOWNSHIP
PUBLIC HEARING & REGULAR BOARD MEETING
APPROVED MINUTES – JUNE 4, 2019 – PAGE 13**

_____, _____ Michigan, as the Bond Registrar (the “Bond Registrar”), together with the interest thereon to the Registered Owner of this Bond on the applicable date of record at the Interest Rate per annum specified above payable on January 1, 2020, and semiannually thereafter on the first day of July and January in each year. The date of record for payments of interest shall be December 15 with respect to payments made on January 1 and June 15 with respect to payments made on July 1.

This Bond is one of a series of bonds (the “Bonds”) of like date and tenor except as to denomination, date of maturity and interest rate, numbered from 1 upwards, aggregating the principal sum of \$_____ issued by the Township under and pursuant to and in full conformity with the Constitution and statutes of the State of Michigan, including pursuant to Act No. 188, Public Acts of Michigan, 1954, as amended, and a resolution duly adopted by the Township Board of Trustees on June 4, 2019. The Bonds are being issued for the purpose of paying a portion of the cost of making certain improvements in a special assessment district in the Township. The Bonds are issued in anticipation of the collection of, and are payable primarily from, certain special assessments made against the benefitted lands in such district. Additionally, the Township has irrevocably pledged its limited tax full faith and credit as security for the payment of the principal of and interest on the Bonds. Pursuant to such pledge, if such special assessments collections are insufficient to pay such principal and interest, the Township is required to pay the principal of and interest on the Bonds as a first budget obligation from its general funds, including the collection of any ad valorem taxes which the Township is authorized to levy, but any such levy shall be subject to applicable constitutional, charter and statutory tax rate limitations.

Bonds maturing in years 20__ to 20__, inclusive, are not subject to optional redemption prior to maturity. Bonds maturing in the years 20__ and thereafter are subject to optional redemption, in whole or in part in such order as the Township shall determine, in integral multiples of \$1,000 on any date on or after July 1, 20__, at par plus accrued interest to the redemption date.

With respect to partial redemptions, any portion of a Bond outstanding in a denomination larger than the minimum authorized denomination may be redeemed provided such portion and the amount not being redeemed each constitutes an authorized denomination. If less than the entire principal amount of a Bond is called for redemption, upon surrender of the Bond to the Bond Registrar, the Bond Registrar shall authenticate and deliver to the registered owner of the Bond a new Bond in the principal amount of the principal portion not being redeemed.

Notice of redemption shall be sent to the registered holder of each Bond being redeemed by first class United States mail at least 30 days before the date fixed for redemption, which notice shall fix the date of record with respect to the redemption. Any defect in any notice of redemption shall not affect the validity of the redemption proceedings. Bonds so called for redemption shall not bear interest after the date fixed for redemption provided funds or sufficient government obligations then are on deposit with the Township to redeem such Bonds.

**TYRONE TOWNSHIP
PUBLIC HEARING & REGULAR BOARD MEETING
APPROVED MINUTES – JUNE 4, 2019 – PAGE 14**

This Bond is transferable on the bond registration books of the Bond Registrar upon surrender of this Bond together with an assignment executed by the Registered Owner or his or her duly authorized attorney in form satisfactory to the Bond Registrar. Upon such transfer, one or more fully registered bonds with denominations of \$1,000, or any multiple of \$1,000, in the same aggregate principal amount and the same maturity and interest rate, will be issued to the designated transferee or transferees. The Bond Registrar shall not be required to honor any transfer of Bonds during the period from the applicable date of record preceding an interest payment date to such interest payment date.

It is hereby certified, recited and declared that all acts, conditions and things required to exist, happen and be performed precedent to and in connection with the issuance of this Bond existed, have happened and have been performed in due time, form and manner as required by the Constitution and statutes of the State of Michigan, and that the total indebtedness of the Township, including this series of Bonds, does not exceed any constitutional limitation.

This Bond is designated as a “qualified tax-exempt obligation” under Section 265(b) of the Internal Revenue Code of 1986, as amended.

IN WITNESS WHEREOF, Tyrone Township, Livingston County, Michigan, has caused this Bond to be executed in its name with the facsimile signatures of its Supervisor and its Clerk, all as of the Date of Issuance.

Tyrone Township

By: _____
Township Supervisor

By: _____
Township Clerk

CERTIFICATE OF AUTHENTICATION

This Bond is one of the series of Bonds designated “Tyrone Township Irish Hills Subdivision Road Improvement Project Special Assessment Bonds, Series 2019 (Limited Tax General Obligation).”

Date of Authentication:

_____, Michigan,
as Bond Registrar and Authenticating Agent
By:

Authorized Signer

**TYRONE TOWNSHIP
PUBLIC HEARING & REGULAR BOARD MEETING
APPROVED MINUTES – JUNE 4, 2019 – PAGE 15**

ASSIGNMENT

For value received, the undersigned sells, assigns and transfers into _____ this Bond and all rights hereunder and hereby irrevocably appoints _____ attorney to transfer this Bond on the books kept for registration thereof with full power of substitution in the premises.

Dated: _____

Signature

NOTICE: The signature to this assignment must correspond with the name as it appears upon the face of this Bond in every particular.

4. Resolution to establish alternate dates for the July & December Board of Review.

RESOLUTION #190603
TYRONE TOWNSHIP, LIVINGSTON COUNTY

ESTABLISHING ALTERNATE JULY AND DECEMBER
BOARD OF REVIEW DATES

WHERE AS, MCL 211.5b allows the Township Board to establish an alternate date for July and December Board of Review;

THEREFORE, BE IT RESOLVED THAT an alternate date may be established for July Board of Review. The alternate date must be during the week of the third Monday in July.

BE IT FURTHER RESOLVED THAT an alternate date may be established for December Board of Review. The alternate date must be during the week of the second Monday in December.

RESOLVED BY: Trustee Schultz
SUPPORTED BY: Trustee Walker

VOTE: Eden, yes; Pedersen, yes; Pool, yes; Schultz, yes; Walker, yes; Cunningham, yes; Husted, yes.

ADOPTION DATE: June 4, 2019

**TYRONE TOWNSHIP
PUBLIC HEARING & REGULAR BOARD MEETING
APPROVED MINUTES – JUNE 4, 2019 – PAGE 16**

CERTIFICATION OF THE CLERK

The undersigned, being the duly qualified and acting Clerk of Tyrone Township, Livingston County, Michigan, hereby certifies that (1) the foregoing is a true and complete copy of a resolution adopted by the Township Board at a regular meeting, held on June 4, 2019, at which meeting a quorum was present and remained throughout, (2) the original thereof is on file in the records in my office, (3) the meeting was conducted, and public notice thereof was given, pursuant to and in full compliance with the Open Meetings Act (Act No. 267, Public Acts of Michigan, 1976, as amended) and (4) minutes of such meeting were kept and will be or have been made available as required thereby.



Marcella Husted
Township Clerk

5. Approval of the draft newsletter.

Trustee Walker moved to approve the draft of the newsletter to be mailed with the summer tax bills. (Treasurer Eden seconded.) The motion carried; all ayes.

PUBLIC REMARKS

None.

MISCELLANEOUS BUSINESS

None.

ADJOURNMENT

Trustee Walker moved to adjourn. (Trustee seconded.) The motion carried; all ayes. The meeting adjourned at 8:31 p.m.

6/10/2019

TYRONE TOWNSHIP TREASURER'S REPORT

JMM

Period ending May, 2019

TOWNSHIP FUNDS	Interest Ckg	INVESTMENTS ICS	Int Rate	MICHIGAN CLASS	Int Rate Monthly AVG.	FLG PEG CD matures 8/13/19	Int rate	Grand Totals Each Fund
General 101	\$1,911,190.58	\$ 580,811.45	2.29%					\$ 2,492,002.03
Tech Fund 141	\$66,426.85	\$ 5,000.00	2.29%					\$71,426.85
Building & Site 145	\$24,634.39	\$ 365,000.00	2.29%					\$389,634.39
Parks/Recreation 208	\$5,934.23		0.40%					\$5,934.23
Liquor Control 212	\$0.00		0.40%					\$0.00
Road 245	\$8,820.57	\$ 439,224.80	2.29%	\$256,910.43	2.53%			\$ 704,955.80
Revolving 246	\$130,842.77	\$ -	2.29%	\$188,728.44	2.53%			\$ 319,571.21
Right of Way 260	\$7,338.04		0.40%					\$7,338.04
Peg 274	\$121,668.53					\$ 185,650.73	2.29%	\$307,319.26
Lk Tyrone Grant 281	\$0.00		0.40%					\$0.00
Special Assessments								
Jayne Hill Lts 218	\$3,211.46		0.40%					\$3,211.46
Walnut Shores Lts 219	\$768.70		0.40%					\$768.70
Shannon Glen Rubbish 225	\$5,049.23							\$5,049.23
Jayne Hill Rubbish Removal 226	\$25,041.82		0.40%					\$25,041.82
Apple Orchard Rubbish Removal 227	\$5,077.34							\$5,077.34
Silver Lake Rubbish Removal 228	\$13,539.18							\$13,539.18
Parkin Lane Snow 231	\$16,932.64		0.40%					\$16,932.64
Great Oaks Dr 232	\$8,325.97		0.40%					\$8,325.97
Account Totals	\$2,354,802.30	\$ 1,390,036.25		\$445,638.87		\$ 185,650.73		\$ 4,376,128.15
Health Flex Spending 101		The State Bank						Health Flex Total
FSA Account (\$10K Loan to Open)		\$ 7,472.10	0.00%					\$ 7,472.10
								\$ 7,472.10
Public Safety- 205								
Public Safety 205 - State Bank checking		\$ 505,793.78	0.40%					\$ 505,793.78
Public Safety 205- State Bank Savings		\$ 6,353.64						\$ 6,353.64
Public Safety 205 - Level One Bank		\$ 203,845.08	0.40%					\$ 203,845.08
Public Safety ICS- 205 State Bank		\$ 752,456.12	2.29%					\$ 752,456.12
								\$ 1,468,448.62
TYRONE TOWNSHIP SEWER 2003- 392								
		Flagstar						Tyrone Sewer 03 Total
Debt Service 392 Flagstar Bank		\$ 400,874.68	0.6%					\$ 400,874.68
Flagstar CDARS 2003 (matures 10/25/2019)(9361)		\$ 528,664.99	2.00%					\$ 528,664.99
Flagstar CD 2003 (matures 3/31/2020)(3879)		\$ 1,000,000.00	2.55%					\$ 1,000,000.00
Flagstar CDARS 2003 Fund Martures 6/20/19)(0913)		\$ 450,000.00	2.00%					\$ 450,000.00
								\$ 2,379,539.67
Road Improvements-								
		Flagstar						Road Improvement Total
Parkin Lane Rd 2010 (396)		\$ 47,006.62	0.70%					\$ 47,006.62
Lake Shannon 2018 (399)		\$ 326,598.77	0.70%					\$ 326,598.77
Laurel springs (400)		\$ 53,526.53	0.70%					\$ 53,526.53
CIBC- Parkin Lane CD(matures 5/12/20)		\$ 124,293.91	2.50%					\$ 124,293.91
								\$ 551,425.83
SEWER O&M CHECKING ACCT- 590								
		Flagstar						Sewer O&M Total
Sewer Operation and Maintenance CK (5710)		\$ 262,978.11	0.70%					\$ 262,978.11
Sewer Operation and Maintenance SV (4865)		\$ 81,552.70	1.39%					\$ 81,552.70
CIBC- O&M CD(matures 5/8/20)(6337)		\$ 158,175.68	2.50%					\$ 158,175.68
O&M CDARS (matures 8/15/2020)(9878)		\$ 138,920.35	0.75%					\$ 138,920.35
O&M CDARS (matures 8/13/2020)(4710)		\$ 138,874.68	2.50%					\$ 138,874.68
								\$ 780,501.52
TRUST & AGENCY- 701								
		Chase						Trust & Agency Total
Township Trust and Agency 701 Savings		\$ 1,510.18	0.18%					\$ 1,510.18
Township Trust and Agency 701 Checking		\$ 7,780.65	0.00%					\$ 7,780.65
								\$ 9,290.83
								\$ 5,196,678.57
Total Township Monies								\$ 9,572,806.72

Check Date	Bank	Check	Vendor Name	Description	Amount
Bank 001 STATE BANK COMMON ACCOUNT					
06/05/2019	001	21887	AMERIGUARD SELF MINI STORAGE	STORAGE UNIT JULY 2019	80.00
06/05/2019	001	21888	CHASE CARD SERVICE	POSTAGE, TRAINING (TREAS, ZON ADMIN, ASS	1,017.00
06/05/2019	001	21889	CONSUMERS ENERGY	TWP HALL ELECTRIC 4.26.19 TO 5.27.19	339.14
06/05/2019	001	21890	CONSUMERS ENERGY	8420 RUNYAN LK ELECTRIC 4.24.19 TO 5.28.	84.90
06/05/2019	001	21891	GRIFFIN PEST SOLUTIONS, INC	HALL PEST CONTROL 5.30.19	44.00
06/05/2019	001	21892	LIVINGSTON COUNTY MUNICIPAL	LCMCA 2019-2020 DUES	20.00
06/05/2019	001	21893	LIVINGSTON COUNTY TREASURER	DOG LICENSES 1839-1871 SOLD MAY 2019	705.50
06/05/2019	001	21894	PRINTING SYSTEMS, INC.	AV BALLOT OUTER ENVELOPES	149.84
06/05/2019	001	21895	PRINTING SYSTEMS, INC.	AV BALLOT RETURN ENVELOPES	142.23
06/05/2019	001	21896	REPUBLIC SERVICES#237	SILVER LAKE ESTAES GARBAGE JUNE 2019	1,149.20
06/05/2019	001	21897	REPUBLIC SERVICES#237	JAYNE HILL GARBAGE JUNE 2019	1,588.73
06/05/2019	001	21898	REPUBLIC SERVICES#237	SHANNON GLEN GARBAGE JUNE 2019	354.51
06/05/2019	001	21899	RITTER'S CLEANING SERVICE	OFFICE CLEANING MAY 2019	825.00
06/05/2019	001	21900	STAPLES ADVANTAGE	OFFICE SUPPLIES; GENERAL, SUPERVISOR, TR	777.39
06/05/2019	001	21901	VIEW NEWSPAPER GROUP	PUBLICATIONS: BOARD, ZBA IRISH HILLS SAD	1,351.36
06/10/2019	001	21902	53RD DISTRICT COURT	SMALL CLAIMS FILING GERALD BARNETT	25.00
06/10/2019	001	21903	KCI	POSTAGE FOR SUMMER TAX BILLS	1,666.05
06/10/2019	001	21904	AT&T MOBILITY	SUPERVISOR CELL 5.28.19 TO 6.27.19	96.62
06/10/2019	001	21905	CHARTER BUSINESS COMMUNICATIONS	TWP HALL & INTERNET JUNE 2019	329.91
06/10/2019	001	21906	CONSUMERS ENERGY	STREET LIGHTING MAY 2019	315.62
06/10/2019	001	21907	DOUGIE'S DISPOSAL & RECYCLING	APPLE ORCHARD GARBAGE JULY-SEPT 2019	1,599.00
06/10/2019	001	21908	GABRIDGE & COMPANY, PLC	AUDIT SERVICES	6,500.00
06/10/2019	001	21909	HARRIS & LITERSKI ATTORNEYS AT	LEGAL-ORD ENF, ZONING ADMIN, BOARD, IRIS	2,588.85
06/10/2019	001	21910	IRON MOUNTAIN INC	DOCUMENT SHREDDING 5.9.19 AND EXTRA SERV	200.81
06/10/2019	001	21911	LIVINGSTON COUNTY ASSESSOR'S ASSOC.	MEMBERSHIP DUES 2019-2020 BRUCE LITTLE	10.00
06/10/2019	001	21912	LIVINGSTON COUNTY ASSESSOR'S ASSOC.	MEMBERSHIP DUES 2019-2020 ALEXA HUSPEK	10.00
06/10/2019	001	21913	LIVINGSTON COUNTY GIS	ASSESSING LAND VALUE & SALES MAP	172.00
06/10/2019	001	21914	RICOH USA, INC.	COPIER LEASE 5.28.19 TO 6.27.19	124.21
06/10/2019	001	21915	RICOH USA, INC.	4607 B&W, 1678 COLOR COPIES	124.08
06/10/2019	001	21916	SOUTHERN LAKES PARKS & RECREAT	PEG DISTRIBUTION	1,335.43
001 TOTALS:					
Total of 30 Checks:					23,726.38
Less 0 Void Checks:					0.00
Total of 30 Disbursements:					23,726.38
Bank 022 STATE BANK - PUBLIC SAFETY checking					
06/05/2019	022	1137	TRANSUNION RISK DATA SOLUTIONS	PEOPLE SEARCH MAY 2019	57.70
06/10/2019	022	1138	HARTLAND AREA FIRE DEPARTMENT	4 FIRE RUNS MAY 1-15	5,676.00
022 TOTALS:					
Total of 2 Checks:					5,733.70
Less 0 Void Checks:					0.00
Total of 2 Disbursements:					5,733.70
Bank 112 FLAGSTAR CHECKING - SA ROAD IMPROVEMENTS					
06/05/2019	112	1018	HUNTINGTON NATIONAL BANK	PARKIN LANE BOND INTEREST & PRINCIPAL	28,607.50
06/05/2019	112	1019	US BANK	LAKE SHANNON DEBT PAYMENT	86,981.25
112 TOTALS:					
Total of 2 Checks:					115,588.75

06/13/2019 09:55 AM
User: MHUSTED
DB: Tyrone

CHECK REGISTER FOR TYRONE TOWNSHIP
CHECK DATE FROM 05/30/2019 - 06/13/2019

Page: 2/2

Check Date	Bank	Check	Vendor Name	Description	Amount
Less 0 Void Checks:					0.00
Total of 2 Disbursements:					115,588.75
Bank 203 TRUST & AGENCY 701 CKG					
06/05/2019	203	1785	CROMAINE LIBRARY	2018 DPPT 5.1.19 TO 5.31.19	6.15
06/05/2019	203	1786	HARTLAND CONSOLIDATED SCHOOLS	2018 DPPT 5.1.19 TO 5.31.19	35.24
06/05/2019	203	1787	LESA	2018 DPPT 5.1.19 TO 5.31.19	14.45
06/05/2019	203	1788	LIVINGSTON COUNTY TREASURER	2018 DPPT 5.1.19 TO 5.31.19	43.27
06/05/2019	203	1789	TYRONE TOWNSHIP	2018 DPPT 5.1.19 TO 5.31.19	8.49
06/10/2019	203	1790	HARRIS & LITERSKI ATTORNEYS AT	LEGAL-CIDER MILL AMENDMENT	660.00
06/10/2019	203	1791	LIVINGSTON COUNTY TREASURER	SPECIFIC MOBILE HOME TAX & SET MAY 2019	1,922.50
06/10/2019	203	1792	TYRONE TOWNSHIP	SPECIFIC MOBILE HOME TAX & INTEREST MAY	384.73

203 TOTALS:

Total of 8 Checks:					3,074.83
Less 0 Void Checks:					0.00
Total of 8 Disbursements:					3,074.83

REPORT TOTALS:

Total of 42 Checks:					148,123.66
Less 0 Void Checks:					0.00
Total of 42 Disbursements:					148,123.66

COMMUNICATION #1

TYRONE TOWNSHIP PLANNING COMMISSION
REGULAR MEETING SYNOPSIS
June 11, 2019 7:00 p.m.

Present: Mark Meisel, Dave Wardin, Kurt Schulze, Rich Erickson, Al Pool, and Bill Wood.

Absent: Perry Green.

Approved the agenda as presented.

APPROVAL OF THE MINUTES:

- 1) April 17, 2019 Regular Meeting – Were approved as presented.
- 2) May 14, 2019 Regular Meeting and Public Hearing – Were approved as amended.

OLD BUSINESS:

- 1) Master Plan 5 Year Update Draft Resolution – The resolution was adopted and will be forwarded to the Township Board for their consideration.
- 2) Animal Units – Was deferred to a future meeting.

NEW BUSINESS:

- 1) Proposed Amendment of Section 21.14 - Home Occupations – Was reviewed and further developed.
- 2) Proposed Amendment of Section 21.21 – Pools – Was reviewed, requires further discussion.
- 3) Proposed Amendment of Section 26.04.A - Permitted Extension or Expansion – Was reviewed.
- 4) Proposed Amendment of Site Line Review Standards – Was reviewed, requires further development.

MISCELLANEOUS BUSINESS:

- 1) Other Business Items: A workshop meeting was scheduled for Thursday, 6/20, at 6:00 P.M.

ADJOURNMENT: The meeting adjourned at 9:51 P.M.

COMMUNICATION #2

1 **TYRONE TOWNSHIP PLANNING COMMISSION**
2 **REGULAR MEETING MINUTES**

3 **April 17, 2019 6:00 p.m.**
4
5

6 **PRESENT:** Mark Meisel, Dave Wardin, Kurt Schulze, and Al Pool
7

8 **ABSENT:** Bill Wood and Perry Green
9

10 **OTHERS PRESENT:** Tyrone Township Planner Greg Elliott and Tyrone Township Planning &
11 Zoning Administrator Ross Nicholson
12

13 **CALL TO ORDER (6:08 pm):** The meeting was called to order by Chairman Mark Meisel.
14

15 **PLEDGE OF ALLEGIANCE (6:09 pm):**
16

17 **CALL TO THE PUBLIC (6:10 pm):**
18

19 Chairman Meisel asked if there was anyone in attendance who had any public comments or
20 questions for the Planning Commission.
21

22 Sid Martin, representing the Shannon Glen Homeowners Association, stated that he has some
23 concerns regarding the property south of the Shannon Glen site condominium (Parcel # 4704-32-
24 100-010). He stated that he believes the owner of said parcel intends to develop the property and
25 potentially use the Shannon Glen private road system to provide access. He stated that the
26 property was initially intended to be developed as a second phase to Shannon Glen (proposed as
27 Shannon Ridge), but the application was denied by the Township. He stated that his primary
28 concern with the development of the parcel is the extension of their existing private road system.
29 He cited from the Tyrone Township Zoning Ordinance that private roads cannot exceed 1,200
30 feet in length and could only serve a specific number of units. He asked the Planning
31 Commission how they would treat the application if/when the property owner submits an
32 application to develop the parcel and if they had any additional thoughts, comments, or
33 suggestions. Chairman Meisel explained that there are many factors that must be considered
34 when reviewing subdivision and site condominium developments so there is no way to provide a
35 valid opinion on the scenario without seeing some kind of plans depicting a proposed layout. He
36 stated that the Planning Commission would be able to comment if they receive an application.
37 He also explained the public hearing notice requirements and indicated that Mr. Martin would
38 receive a notice of the hearing by mail if his property is within three hundred (300) feet of the
39 subject property. He also indicated that a notice would be published in the Tri County Times and
40 posted at the Township Hall/website at least fifteen (15) days prior to the hearing.
41

42 **APPROVAL OF THE AGENDA (7:04 pm):**
43

44 Kurt Schulze made a motion to approve the agenda as presented. Dave Wardin supported the
45 motion. Motion carried by unanimous voice vote.

46 Dave Wardin made a motion to suspend the order of business to place New Business Item #1
47 (Gruber Land Division) ahead of all other business items in consideration of the applicant in
48 attendance. Al Pool supported the motion. Motion carried by unanimous voice vote
49

50 **APPROVAL OF THE MINUTES (6:23 pm):**

51
52 Deferred (no minutes available).
53

54 **NEW BUSINESS #1 (6:23 pm): Gruber Land Division:**

55
56 Greg Elliott introduced the topic with a summary of the land division application before reading
57 through the McKenna review letter he had prepared. Chairman Meisel brought up the
58 application documents and Zoning Ordinance on the overhead monitors. Greg Elliott stated that
59 one of the requirements that had not been fulfilled is the documentation pertaining to the
60 proposed shared private driveway that would provide access to two proposed parcels. He noted
61 that there was only an example shared private driveway on the drawing where the Zoning
62 Ordinance requires additional details including dimensions, legal description(s), cross-section
63 drawings, and a maintenance agreement in recordable form, along with Livingston County Road
64 Commission location approval.
65

66 The Planning Commission briefly discussed the application, primarily the site area for proposed
67 Parcel 1. Proposed Parcel 1 would fall shy of the minimum parcel size requirement for the R-1
68 zoning district once the submerged land (part of Marl Lake) is subtracted from the calculation.
69 The Planning Commission briefly discussed the parcel size issue. It was determined that the
70 applicant would need to apply for a variance through the Zoning Board of Appeals (ZBA) for a
71 reduction in the minimum required parcel area, make revisions to the drawings and legal
72 descriptions, and submit additional documentation pertaining to the shared private driveway.
73 The variance will need to be granted in order for the land division to be considered for approval
74 as proposed (specifically the proposed configuration of Parcel 1).
75

76 Dave Wardin made a motion to table the Gruber Land Division application pending a ZBA
77 variance for a reduction in site area for proposed Parcel 1, revisions to the drawings and legal
78 descriptions (as requested), and documents pertaining to the proposed shared private driveway.
79 Kurt Schulze supported the motion. Motion carried by unanimous voice vote.
80

81 *The item was closed at 7:43 pm.*
82

83 **OLD BUSINESS # 2 (7:47 pm): Animal Units Discussion**

84
85 Dave Wardin provided a copy of the latest draft he had prepared on the topic of keeping of
86 animals for private use (currently “Animal Units”- Section 21.28.E, Tyrone Township Zoning
87 Ordinance #36). He read through the draft and indicated which areas had been changed since the
88 last discussion. The Planning Commission briefly discussed next steps, which includes a review
89 by Greg to potentially reorganize the text for better flow.
90

91 *The item was closed at 8:01 pm.*

92
93
94
95
96
97
98
99
100
101
102
103
104
105
106
107
108

OLD BUSINESS #1 (8:02 pm): Sign Regulations:

Chairman Meisel briefly reminded the Planning Commission where the discussion had left off on the proposed sign amendments. He stated that the last remaining item that will need to be discussed, prior to recommending adoption, is the violation and fine structure. It was suggested the McKenna memo detailing the current civil infraction process be forwarded to the Township Board as a recommended review action.

The item was closed at 8:04 pm.

MISCELLANIOUS BUSINESS (8:04 pm): Bentley Sand and Gravel Consent Agreement

Chairman Meisel and Dave Wardin briefly discussed conditions for a consent judgement that had been determined in a subcommittee meeting prior to the regular Planning Commission meeting with representatives from Bentley Sand and Gravel.

The meeting was adjourned at 8:06 pm by Chairman Meisel.

COMMUNICATION #3

1 **TYRONE TOWNSHIP PLANNING COMMISSION**
2 **REGULAR MEETING & PUBLIC HEARING MINUTES**

3 **May 14, 2019 7:00 p.m.**
4
5

6 **PRESENT:** Mark Meisel, Dave Wardin, Kurt Schulze, Al Pool, and Perry Green
7

8 **ABSENT:** Rich Erickson and Bill Wood
9

10 **OTHERS PRESENT:** Tyrone Township Planner Greg Elliott and Tyrone Township Planning &
11 Zoning Administrator Ross Nicholson
12

13 **CALL TO ORDER (7:03 pm):** The meeting was called to order by Chairman Mark Meisel.
14

15 **PLEDGE OF ALLEGIANCE (7:03 pm):**
16

17 **CALL TO THE PUBLIC (7:03 pm):**
18

19 Chairman Meisel asked if there was anyone in attendance who had any public comments or
20 questions for the Planning Commission. A resident introduced herself as Megan Messimer and
21 stated that she was the applicant for the home occupation application. Chairman Meisel stated
22 that they would go through the application shortly and thanked her for her attendance.
23

24 **APPROVAL OF THE AGENDA (7:04 pm):**
25

26 Dave Wardin made a motion to approve the agenda as presented. Al Pool supported the motion.
27 Motion carried by unanimous voice vote.
28

29 **APPROVAL OF THE MINUTES (7:04 pm):**
30

31 April 9, 2019 Regular Meeting Minutes:
32

33 Minor revisions were made to the draft to correct errors and add clarification. Dave Wardin
34 made a motion to approve the April 9, 2019 Regular Meeting Minutes as amended. Kurt Schulze
35 supported the motion. Motion carried by unanimous voice vote.
36

37 *Dave Wardin made a motion to suspend the order of business to place New Business Item #1*
38 *(Messimer Home Occupation) in front of all other business items in consideration of the*
39 *applicant in attendance. Al Pool supported the motion. Motion carried by unanimous voice*
40 *vote.*
41

42 **NEW BUSINESS #1 (7:06 pm): Messimer Home Occupation:**
43

44 Chairman Meisel brought up the application documents and Zoning Ordinance on the overhead
45 monitors. Megan Messimer (applicant) briefly explained her intent to open a small business
46 where she would make hats in her home and sell them online and offsite. The Planning

47 Commission reviewed the application per the standards in the Zoning Ordinance pertaining to
48 home occupations. All were in agreement that the standards for approval had been met. The
49 Planning Commission noted that the proposed use would be very low impact and it would be
50 unlikely that it would generate any significant nuisance factors that would be of greater intensity
51 than a typical single-family dwelling. The Planning Commission also noted that they should
52 revisit the approval standards for permitted home occupations at a later date to determine
53 whether or not they should be amended for low impact uses.

54

55 Dave Wardin made a motion to approve the Messimer Home Occupation application. Kurt
56 Schulze supported the motion. Motion carried by unanimous voice vote.

57

58 *The item was closed at 7:18 pm.*

59

60 **OLD BUSINESS # 1 (7:19 pm): Animal Units:**

61

62 Chairman Meisel introduced the topic with a summary of where the Planning Commission had
63 left off on discussion of the topic. He stated that Dave Wardin had prepared a rough draft for an
64 ordinance which he had put together after researching standards from several municipalities
65 across the country. He continued, stating that Greg was directed to take the information from
66 that draft and the suggestions and comments from the Planning Commission's previous
67 discussion and prepare a more structured draft. Greg Elliot indicated that he did not have the
68 opportunity to prepare the draft. Chairman Meisel suggested that the Planning Commission
69 continue discussion based on the draft Dave Wardin had prepared.

70

71 Chairman Meisel briefly skimmed through the draft ordinance and the Planning Commission
72 discussed various elements. Chairman Meisel asked Dave Wardin where he came up with the
73 definitions and calculations for different animal classifications. Dave Wardin stated that he had
74 acquired the information from ordinances from various municipalities. He noted that most of the
75 definitions for classifications and calculations from the different municipalities are virtually the
76 same. Chairman Meisel asked if he was able to find any further information in terms of
77 explanations for why certain amounts were set for specific classifications and categories. Dave
78 Wardin indicated that he did not find any specific explanations or reasoning behind the amounts.
79 Dave Wardin stated that he had updated the draft to include a statement that would prohibit the
80 keeping of animals on property within the jurisdiction of any association with bylaws prohibiting
81 them, as had been suggested during the last discussion.

82

83 *The meeting was temporarily recessed at 7:33 pm for a public hearing pertaining to proposed*
84 *Zoning Ordinance Amendments including; Lot Area for Land Division Clarifications,*
85 *Recreational Marijuana, and Solar Farms.*

86

87 *Chairman Meisel called the public hearing to order and read through the Public Hearing Notice*
88 *that was published in the Tri-County Times on Sunday, April 28, 2019, in compliance with the*
89 *Open Meetings Act (Below).*

**TYRONE TOWNSHIP PLANNING COMMISSION
PUBLIC HEARING AGENDA
May 14, 2019 7:30 p.m.**

The notice below was published in the Tri-County Times on Sunday, April 28, 2019, in compliance with the Open Meetings Act.

**TYRONE TOWNSHIP PLANNING COMMISSION
NOTICE OF PUBLIC HEARING**

Notice is hereby given the Tyrone Township Planning Commission will hold a Public Hearing on Tuesday, May 14, 2019, beginning at 7:30 pm at the Tyrone Township Hall, 10408 Center Road, Fenton, Michigan 48430. The purpose for the Public Hearing is:

To receive public comments regarding proposed amendments to Zoning Ordinance #36:

1. Solar Farms: Article 21, Section 21.46 - Essential Public Services and Required Utilities, to modify commercial solar energy production requirements;
2. Recreational Marijuana: Article 21, Section 21.59 –Recreational Marijuana Uses (new), to prohibit recreational marijuana facilities and establishments in all zoning districts;
3. Lot Area for Land Divisions: Article 2, Section 2.01- Definitions & Article 20, Section 20.02- Footnotes to Schedule of Regulations (Note W), to add a definition for submerged land and modify requirements for lot area calculations.

Additional information is available at the Tyrone Township Clerk’s Office, 10408 Center Road, Monday through Thursday, 9 a.m. to 5 p.m. Individuals with disabilities requiring auxiliary aids or services should contact the Tyrone Township Clerk, at (810) 629-8631, at least seven days prior to the meeting.

Mark Meisel, Chairman

Tyrone Township Planning Commission

90
91

PUBLIC HEARING #1 (7:34 pm): Solar Farms:

93

Chairman Meisel brought up a document on the overhead monitors which included the existing and proposed ordinance text for Solar Farm regulations (Zoning Ordinance #36, Section 21.46- Essential Public Services and Required Utilities). He read through the existing text and the proposed amendments item by item, briefly explaining the intent and reasoning for each proposed change.

99

Chairman Meisel asked if there was anyone in attendance who had any questions or comments regarding the proposed solar farm regulation amendments.

102

Irvin Ridenour asked if there were any current or pending applications for solar farms at this time. Chairman Meisel stated that there have been companies that have contacted the Township inquiring about the requirements and standards, but there are no current or pending applications. He continued, stating that the amendments are being proposed so that solar farms can be adequately reviewed and regulated if or when an application is received.

108

A resident (name not stated) asked if the proposed amendments to the solar farm regulations would apply to individual/residential or just to large-scale energy production facilities.

110

Chairman Meisel explained that these amendments would only apply to commercial energy

111

112 production facilities. He continued, explaining that the regulations for commercial facilities
113 should allow farmers to utilize more land that could otherwise not be used for agriculture or
114 when rotating crops.

115
116 There was a brief discussion amongst the Planning Commission regarding how solar farms can
117 be assessed in terms of taxes. It was determined that there are a number of unknowns surrounding
118 how solar farms can be assessed.

119
120 Chairman Meisel asked if there were any additional comments or questions regarding the
121 proposed solar farm amendments. No comments or questions were received.

122
123 **PUBLIC HEARING #2 (7:53 pm): Recreational Marijuana:**

124
125 Chairman Meisel introduced the topic and read the proposed new text pertaining to recreational
126 marijuana (Section 21.59.A- Below).

127
128 “**Licensed Recreational Marijuana Establishments/Facilities.** Tyrone Township elects to opt out,
129 and therefore prohibits, any and all establishments eligible to be licensed for recreational Marijuana
130 uses by the State of Michigan and/or Tyrone Township, inclusive of qualifying recreational
131 marijuana facilities, in all zoning districts.”

132
133 He explained that the proposed text is intended to be consistent with the Township Board’s
134 resolution to prohibit all recreational marijuana facilities/establishments in the Township. He
135 noted that this section would be new and not an amendment to an existing section.

136
137 Greg Elliott recommended using the term “adult use” to describe the “qualifying recreational
138 marijuana facilities” since that is the terminology that is currently being used at the State level.
139 A brief discussion amongst the Planning Commission followed regarding the use of the term
140 “adult use”. Chairmen Meisel suggested researching the term further before committing to the
141 amendment.

142
143 Danica Katnik (WHMI 93.5 FM) asked the Planning Commission why the proposed text is
144 necessary if the Township Board has already resolved to prohibit all recreational marijuana
145 facilities in the Township through a regulatory ordinance. She continued, stating that the term
146 “adult use” might imply that persons who are at least eighteen (18) years of age could legally use
147 recreational marijuana since they are considered to be “adults” in the State of Michigan. She
148 asked what the benefit of including the term would be if it doesn’t clearly specify that
149 recreational marijuana use would be limited to persons at least twenty-one (21) years of age or
150 older. Chairman Meisel explained that the regulatory ordinance is intended to act as a first
151 defense which would affect all properties within the Township. He continued, stating that the
152 Zoning Ordinance allows “grandfathering” or continued use of an existing nonconformity,
153 sometimes subject to restrictions. He stated that it is best to add the Zoning Ordinance language
154 to reduce the likelihood of future conflicts from a location or zoning point of view and reinforces
155 the existing regulations. Greg Elliott added that the proposed text would also benefit the
156 Township if they decide to opt in for all/certain aspects of recreational marijuana since it would
157 give the Township more time to establish sound regulations as it takes up to ninety (90) days

158 from the date of application to approval or denial of licensed recreational marijuana facilities
159 through the State of Michigan. A brief discussion amongst the Planning Commission followed.
160 The consensus was that the proposed text may be redundant and ultimately may not even be
161 necessary, however, there is a chance it could be beneficial and the Township Board gave
162 direction to the Planning Commission to work on drafting language to be incorporated into the
163 Zoning Ordinance.

164
165 Chairman Meisel asked if there were any further questions or comments regarding the proposed
166 Zoning Ordinance text to prohibit all recreational marijuana facilities. No comments or
167 questions were received.

168
169 **PUBLIC HEARING #3 (8:11 pm): Lot Area for Land Divisions:**

170
171 Chairman Meisel opened the discussion with a brief summary of why the amendment was
172 proposed. He explained that there was a recent land division application in which one of the
173 proposed parcels would include land area that was completely submerged (part of a lake) into the
174 parcel area calculation, which is not the intent of the Zoning Ordinance. He continued, stating
175 that the proposed text would require certain submerged lands to be subtracted from the total
176 parcel area for the purposes of dividing land. The proposed text would be included in Section
177 2.01 (Definitions) and Section 20.02 (Footnotes to Schedule of Regulations) in the Zoning
178 Ordinance. The proposed language is below:

179
180 **“SECTION 2.01 DEFINITIONS**
181 **SUBMERGED LAND:** The land under the ordinary high-water mark of an inland lake, pond,
182 river, or stream owned by a riparian property owner, as defined by Michigan Public Act 451
183 of 1994.”

184
185 **“SECTION 20.02 FOOTNOTES TO SCHEDULE OF REGULATIONS**
186 **W.** Lot areas are measured as the horizontal area within the lot lines or boundaries,
187 exclusive of submerged lands beneath inland lakes. For lots less than ten (10) acres in size,
188 lot area shall not include any area outside of the lot lines including public or private road
189 easements and rights-of-way or dedicated open spaces. Such measurement is often termed
190 the “net area.” However, in the event the easement or right-of-way is associated with a lot of
191 less than ten (10) acres in area and the area of the easement or right-of-way, if added to the
192 lot area, will increase the lot to ten (10) or more acres, then the area of the easement or
193 right-of-way shall be included in the lot area measurement.”

194
195 The Planning Commission briefly discussed the land division application and reviewed the
196 proposed text. Chairman Meisel asked if there were any public comments or questions regarding
197 the topic. None were received.

198
199 *The public hearing was closed at 8:34 pm by Chairman Meisel.*

200
201 Dave Wardin stated he had a comment and question regarding recreational marijuana. He stated
202 that there was a court order issued on January 16th that state licensed facilities must provide all
203 excess product to provisioning centers. He asked if that would create an issue in relation to our
204 current caregiver regulations. Greg Elliot explained the details of how the State has been

205 handling excess product and stated that he did not believe there would be any significant issues
206 with the current caregiver regulations. There was a brief discussion amongst the Planning
207 Commission. Chairman Meisel stated that the language in the Zoning Ordinance is consistent
208 with Initiated Law #1 (MMMA) and will allow the Township to continue enforcing even if the
209 State chooses to stop enforcing in the future.

210

211 **OLD BUSINESS # 1 (8:40 pm): Animal Units Discussion (Continued):**

212

213 The Planning Commission picked up on discussion of the draft ordinance text where they had
214 previously left off. After discussion, the Planning Commission determined that some additional
215 research would be necessary to ensure the proposed regulations would be appropriate. It was
216 suggested that the research includes looking into standards, guidelines, and recommended
217 practices from the Michigan Department of Agriculture and Rural Development (MDARD).

218

219 *The item was closed at 9:34 pm.*

220

221 **OLD BUSINESS #2 (9:35 pm): Sign Regulations:**

222

223 Chairman Meisel introduced the topic with a summary of where the discussion had previously
224 left off. He stated that the Planning Commission previously determined that the majority of the
225 content in the proposed text was ready to move forward, however, there was still some additional
226 review needed before the penalties and enforcement sections would be ready.

227

228 *The item was closed at 9:39 pm.*

229

230 Chairman Meisel asked the Planning Commission is anyone would like to take action on the
231 public hearing agenda items.

232

233 Dave Wardin moved to recommend adoption of the three (3) proposed Zoning Ordinance
234 amendments (Solar Farms, Recreational Marijuana, and Lot Area for Land Divisions) to the
235 Township Board and to forward the amendments to the Livingston County Planning Commission
236 for review and comment. Al Pool supported the motion. Motion carried by unanimous voice
237 vote.

238

239 **MISCELLANIOUS BUSINESS (9:45 pm):**

240

241 Chairman Meisel asked the Planning Commission if Wednesday May 22, 2019 at 6:00 pm would
242 be a good time to hold the next workshop meeting. Most Planning Commissioners confirmed
243 their availability. Chairman Meisel scheduled the workshop meeting for 05/22/2019, beginning
244 at 6:00 pm.

245

246 *The meeting was adjourned at 9:55 pm.*

NEW BUSINESS #1



Tyrone Township

10408 Center Road ♦ Fenton, MI 48430
(810) 629-8631 ♦ fax (810) 629-0047

Application for Employment

Our policy is to provide equal employment opportunity to all qualified persons without regard to race, creed, color, religious belief, sex, age, national origin, ancestry, physical or mental disability, or veteran status. Persons with a disability or handicap needing accommodations to perform the essential duties of the job must disclose that in writing with this application. The Township may require medical documentation.

Date 5/29/19

Last name Stickel First name Daniel Middle name G

Street Address 4015 Bennett Lake Rd.

City Fenton State Mi ZIP 48430 Telephone _____

Are you 18 or older? Yes No

Position applied for Zoning Board of Appeals

How did you hear of this opening? _____

When can you start? Immediately Desired Wage \$ N/A

Are you a U.S. citizen or otherwise authorized to work in the U.S. on an unrestricted basis? (You may be required to provide documentation.) Yes No

Are you looking for full-time employment? Yes No

If no, what hours are you available? _____

Have you ever been convicted of a felony? (This will not necessarily affect your application.)

Yes No

If yes, please describe conditions. _____

Education

	School Name & Address	Year Graduated	Major	Degree
High School	Fenton High School	2001		
College	Lawrence Tech Univ.	2007	Civil	B.S.
College	Baker College	2012	Bus.	MBA
Post-College				
Other Training				

Do you have US Military Experience? Yes No Number of Years Served _____
 Branch _____ Rank _____ Date Discharged _____ Honorably? Yes No

In addition to your work history, are there other skills, qualifications, or experience that we should consider?

City of Fenton - Zoning Board of Appeals 2014-2018

City of Fenton.- Local Development Finance Authority 2014-2018

Employment History (Start with most recent employer)

Company Name Waterford Township DPW

Address 5240 Civic Center Dr. Telephone 248-618-7451

Date Started Sept '12 Starting Wage _____ Starting Position _____

Date Ended _____ Ending Wage _____ Ending Position _____

Name of Supervisor Russell Williams

May we contact? Yes No

Responsibilities Responsible for capital improvements, asset management

Capital planning, general engineering services for DPW

Reason for leaving _____

Company Name Wade Trim, Inc.

Address 555 S. Saginaw, Flint, MI Telephone 810-235-2555

Date Started May '07 Starting Wage _____ Starting Position _____

Date Ended Sept. '12 Ending Wage _____ Ending Position _____

Name of Supervisor John Ciesielski

May we contact? Yes No

Responsibilities Project engineering, project management

Reason for leaving _____

Company Name _____

Address _____ Telephone _____

Date Started _____ Starting Wage _____ Starting Position _____

Date Ended _____ Ending Wage _____ Ending Position _____

Name of Supervisor _____

May we contact? Yes No

Responsibilities _____

Reason for leaving _____

Company Name _____

Address _____ Telephone _____

Date Started _____ Starting Wage _____ Starting Position _____

Date Ended _____ Ending Wage _____ Ending Position _____

Name of Supervisor _____

May we contact? Yes No

Responsibilities _____

Reason for leaving _____

Please read the following statement before signing to indicate your understanding and attach any additional information if necessary.

I certify that the facts set forth in this application for employment are true and complete to the best of my knowledge. I understand that if I am employed, false statements on this application shall be considered sufficient cause for dismissal. The Township is hereby authorized to make any investigations of my background, prior educational, and employment history.

I understand that employment at the Township is "at will," which means that either I or the Township can terminate the employment relationship at any time, with or without prior notice, and for any reason not prohibited by statute. I understand that no supervisor, manager, or executive of the Township, other than the Board of Trustees, has any authority to alter the foregoing.

As a condition of employment, employees of the Township agree not to commence any action or claim, or suit relating to their employment with the Township more than 182 calendar days after the date the employee knew or should have known that a claim existed or later than the applicable limitations period established by statute, whichever is less.

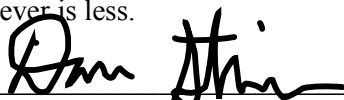
Signature  Date 5/29/2019

NEW BUSINESS #2

**RESOLUTION #1906xx
TYRONE TOWNSHIP, LIVINGSTON COUNTY**

**LAUREL SPRINGS SUBDIVISION
WASTE REMOVAL PROJECT (2019)**

**RESOLUTION TO PROCEED WITH THE PROJECT AND DIRECTING
PREPARATION OF THE PLANS AND COST ESTIMATES**

WHEREAS, the Board of Trustees of the Township has received a petition signed by property owners of the Laurel Springs subdivision of the Township requesting that a single waste hauler be established for the collection and disposal of garbage and rubbish within the Laurel Springs subdivision in the Township as described in Exhibit A (the “Project”);

WHEREAS, the Board of Trustees of the Township desires to establish the Project, and;

WHEREAS, the Board of Trustees of the Township has tentatively determined to proceed with the Project in accordance with Act No. 188, Michigan Public Acts of 1954 as amended, and;

WHEREAS, the Board of Trustees of the Township has tentatively determined to continue to use special assessment funds to pay the costs of the Project;

NOW, THEREFORE, BE IT RESOLVED THAT:

1. In accordance with Act No. 188, Michigan Public Acts of 1954, as amended, and the laws of the State of Michigan, the Township Supervisor is directed to have plans prepared illustrating the Project, the location of the Project, and an estimate of the cost of the Project.

2. The plans and estimates identified in paragraph 1, when prepared, shall be filed with the Township Clerk.

**RESOLVED BY:
SUPPORTED BY:**

VOTE:

ADOPTION DATE: June 18, 2019

CERTIFICATION OF THE CLERK

The undersigned, being the duly qualified and acting Clerk of Tyrone Township, Livingston County, Michigan, hereby certifies that (1) the foregoing is a true and complete copy of a resolution adopted by the Township Board at a regular meeting, held on June 18, 2019, at which meeting a quorum was present and remained throughout, (2) the original thereof is on file in the records in my office, (3) the meeting was conducted, and public notice thereof was given, pursuant to and in full compliance with the Open Meetings Act (Act No. 267, Public Acts of Michigan, 1976, as amended) and (4) minutes of such meeting were kept and will be or have been made available as required thereby.

Marcella Husted
Tyrone Township Clerk

*Resolution #1906xx
Laurel Springs Subdivision Waste Removal Project*

EXHIBIT A

DESCRIPTION OF PROJECT

The project (the "Project") will consist of the establishment of a single waste hauler for the collection and disposal of garbage and rubbish along the following streets in the Laurel Springs subdivision in Tyrone Township: Dentonview Dr., Laurel Springs Blvd., Overlook Dr., and 12231 and 12245 White Lake Rd.

Exhibit A, Page 1

*Resolution #1906xx
Laurel Springs Subdivision Waste Removal Project*

NEW BUSINESS #3

**RESOLUTION #1906xx
TYRONE TOWNSHIP, LIVINGSTON COUNTY**

**LAUREL SPRINGS SUBDIVISION
WASTE REMOVAL PROJECT (2019)**

**RESOLUTION TO APPROVE THE PROJECT,
SCHEDULING THE FIRST HEARING
AND DIRECTING THE ISSUANCE OF STATUTORY NOTICES**

WHEREAS, the Board of Trustees of the Township has received a petition signed by property owners in the Laurel Springs subdivision of the Township requesting that a single waste hauler be established for the collection and disposal of garbage and rubbish within the Laurel Springs subdivision in the Township as described in Exhibit A (the “Project”);

WHEREAS, the Board of Trustees of the Township desires to establish the Project, and;

WHEREAS, the Board of Trustees of the Township has approved the establishment of the Project;

WHEREAS, preliminary plans and cost estimates for the Project have been filed with the Township Clerk;

WHEREAS, the Board of Trustees of the Township has tentatively determined to use special assessments to raise the funds to pay the costs of the Project and has tentatively determined to proceed with the Project;

WHEREAS, the special assessment district (the “Special Assessment District”) for the Project has been tentatively determined by the Township and is described in Exhibit B;

NOW, THEREFORE, BE IT RESOLVED THAT:

1. The Board of Trustees of the Township hereby tentatively declares its intent to proceed with the Project.

2. In accordance with Act No. 188, Michigan Public Acts of 1954, as amended, and the laws of the State of Michigan, there shall be a public hearing on the Project and the proposed Special Assessment District for the Project which is known as the “Tyrone Township Laurel Springs Subdivision Waste Removal Project (2019) Special Assessment District.”

3. The public hearing will be held on Tuesday, July 16, 2019 at 7:00 p.m., at the offices of Tyrone Township, Livingston County, Michigan.

4. The Township Clerk is directed to mail, by first class mail, a notice of the public hearing to each owner of or party in interest in property to be assessed, whose name appears upon the last Township tax assessment records. The last Township tax assessment records means the last assessment roll for ad valorem tax purposes which has been reviewed by the Township Board of Review, as supplemented by any subsequent changes in the names or addresses of such owners or parties listed thereon. The notice to be mailed by the Township Clerk shall be similar to the notice attached as Exhibit B and shall be mailed by first class mail on or before June 25, 2019. Following the mailing of the notices, the Township Clerk shall complete an affidavit of mailing similar to the affidavit set forth in Exhibit C.

5. The Township Clerk is directed to publish a notice of the public hearing in the Tri-County Times, a newspaper of general circulation within the Township. The notice shall be published twice, once on or before June 30, 2019 and once on or before July 14, 2019. The notice shall be in a form substantially similar to the notice attached as Exhibit B.

RESOLVED BY:
SUPPORTED BY:

VOTE:

ADOPTION DATE: June 18, 2019

CERTIFICATION OF THE CLERK

The undersigned, being the duly qualified and acting Clerk of Tyrone Township, Livingston County, Michigan, hereby certifies that (1) the foregoing is a true and complete copy of a resolution adopted by the Township Board at a regular meeting, held on June 18, 2019, at which meeting a quorum was present and remained throughout, (2) the original thereof is on file in the records in my office, (3) the meeting was conducted, and public notice thereof was given, pursuant to and in full compliance with the Open Meetings Act (Act No. 267, Public Acts of Michigan, 1976, as amended) and (4) minutes of such meeting were kept and will be or have been made available as required thereby.

Marcella Husted
Tyrone Township Clerk

*Resolution #1906xx
Laurel Springs Subdivision Waste Removal Project*

EXHIBIT A

DESCRIPTION OF PROJECT

The project (the "Project") will consist of the establishment of a single waste hauler for the collection and disposal of garbage and rubbish along the following streets in the Laurel Springs subdivision in Tyrone Township: Dentonview Dr., Laurel Springs Blvd., Overlook Dr., and 12231 and 12245 White Lake Rd.

Exhibit A, Page 1

*Resolution #1906xx
Laurel Springs Subdivision Waste Removal Project*

EXHIBIT B

FORM OF NOTICE OF PUBLIC HEARING

**Tyrone Township
Livingston County, Michigan**

**NOTICE OF PUBLIC HEARING
UPON SPECIAL ASSESSMENT ROLL FOR THE
TYRONE TOWNSHIP LAUREL SPRINGS SUBDIVISION
WASTE REMOVAL PROJECT (2019) SPECIAL ASSESSMENT DISTRICT**

NOTICE IS HEREBY GIVEN:

(1) The Township Board of Tyrone Township, Livingston County, Michigan (the "Township") in accordance with the laws of the State of Michigan, will conduct a public hearing beginning at 7:00 p.m., local time, on July 16, 2019 at the Tyrone Township Hall, 10408 Center Road, Fenton, Michigan, to review the following proposed special assessment district:

**TYRONE TOWNSHIP LAUREL SPRINGS SUBDIVISION
WASTE REMOVAL PROJECT (2019)
SPECIAL ASSESSMENT DISTRICT**

and to hear any objections thereto and the proposed project.

(2) The project (the "Project") will consist of establishing a single waste hauler for the Laurel Springs subdivision in Tyrone Township. The Project is designed to serve the properties in the Special Assessment District (the "District"), which District consists of the properties located within the area designated on the map attached at Appendix I and includes the specific properties that are identified by the permanent lot and parcel numbers described in Appendix II.

(3) The Township plans to impose special assessments on the properties located in the Special Assessment District to pay for the costs of the Project.

(4) The plans and cost estimates for the proposed Project and the description of the District are now on file in the office of the Township Clerk for public inspection. Periodic redeterminations of the cost of the Project may be made, and subsequent hearings shall not be required if such cost redeterminations do not increase the estimated cost of the Project by more than 10%. Any person objecting to the proposed Project or the proposed District must file his or her objections in writing with the Township Clerk before the close of the July 16, 2019 public hearing or within such additional time (if any) as the Township Board may grant.

This notice is given by order of the Tyrone Township Board.

Dated: June 25, 2019

Marcella Husted
Tyrone Township Clerk

Exhibit B, Page 1

*Resolution #1906xx
Laurel Springs Subdivision Waste Removal Project*

APPENDIX I

Map of Special Assessment District

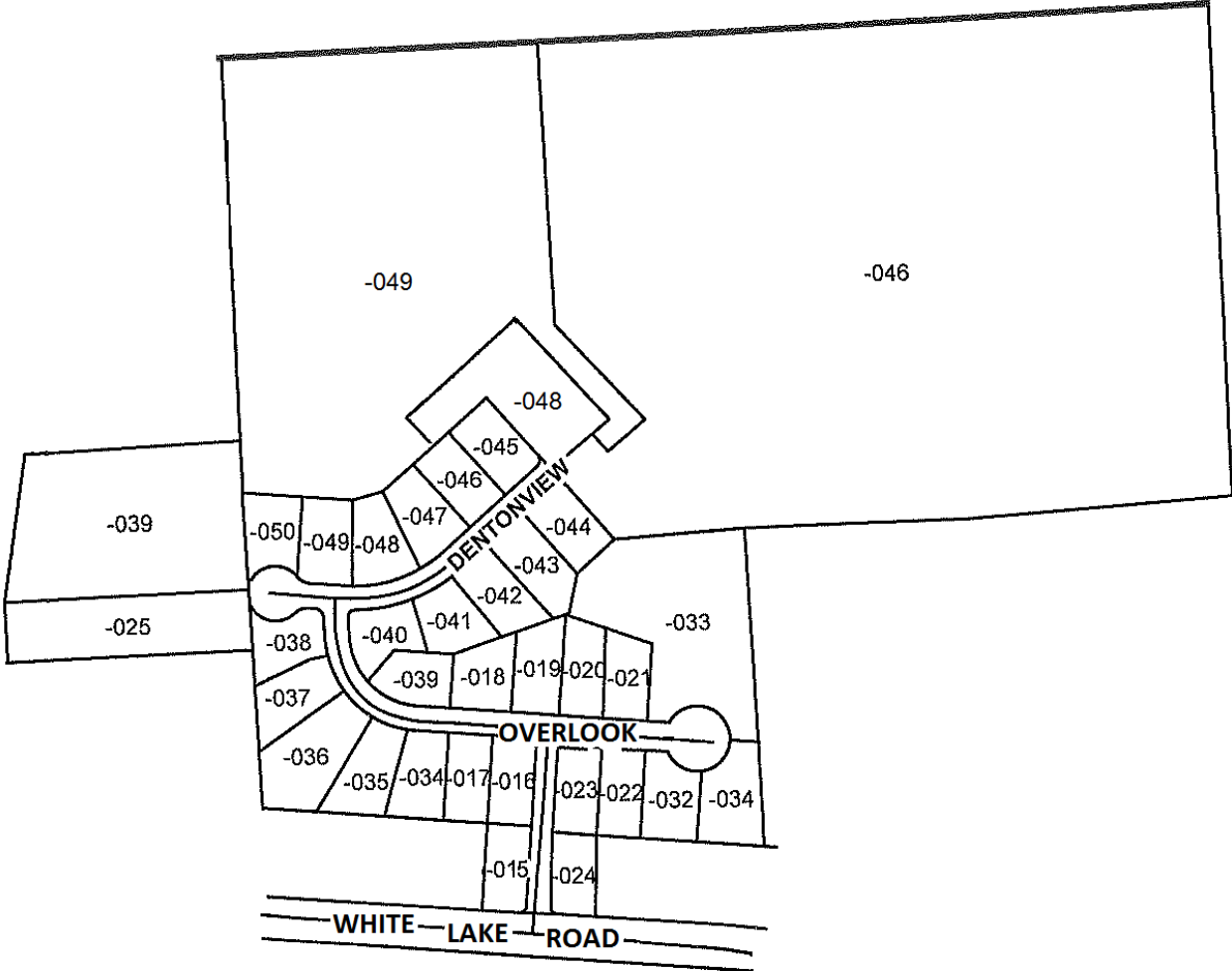

APPENDIX II

Special Assessment District
Permanent Parcel Numbers

4704-11-100-025	4704-11-101-019	4704-11-101-040
4704-11-100-032	4704-11-101-020	4704-11-101-041
4704-11-100-033	4704-11-101-021	4704-11-101-042
4704-11-100-034	4704-11-101-022	4704-11-101-043
4704-11-100-039	4704-11-101-023	4704-11-101-044
4704-11-100-046	4704-11-101-024	4704-11-101-045
4704-11-100-048	4704-11-101-034	4704-11-101-046
4704-11-100-049	4704-11-101-035	4704-11-101-047
4704-11-101-015	4704-11-101-036	4704-11-101-048
4704-11-101-016	4704-11-101-037	4704-11-101-049
4704-11-101-017	4704-11-101-038	4704-11-101-050
4704-11-101-018	4704-11-101-039	

EXHIBIT C

AFFIDAVIT OF MAILING

STATE OF MICHIGAN)
)
COUNTY OF LIVINGSTON)

Marcella Husted, being first duly sworn, deposes and says that she personally prepared for mailing, and did on June 25, 2019, send by first-class mail, the notice of hearing, a true copy of which is attached hereto, to each record owner of or party in interest in all property to be assessed for the improvement described therein, as shown on the last local tax assessment records of the Township of Tyrone; that she personally compared the address on each envelope against the list of property owners as shown on the current tax assessment rolls of the Township; that each envelope contained therein such notice and was securely sealed with postage fully prepaid for first-class mail delivery and plainly addressed; and that she personally placed all of such envelopes in a United States Post Office receptacle on the above date.

Marcella Husted
Tyrone Township Clerk

Subscribed and sworn to before me
this 25th day of June 2019.

Notary Public

_____County, Michigan
Acting in Livingston County
My commission expires:

Exhibit C

NEW BUSINESS #4

**RESOLUTION #1906XX
TYRONE TOWNSHIP, LIVINGSTON COUNTY**

PRIVATE INFRASTRUCTURE SPECIAL ASSESSMENTS POLICY

- A. Before submitting a request for Township involvement in a private infrastructure project, a property owner (or owners) must meet with the Township Supervisor and Clerk (or another Township official or employee designated by the Township Board) to inform the Township of the proposed project, review this Township's Private Infrastructure Special Assessments Policy and discuss other relevant issues relating to the proposed project and the process to establish the special assessment district (SAD). Township project pre-approval is required to advance further into the process. The Township reserves the right to require an escrow deposit for project costs, which include, but are not limited to, administrative expenses, publication costs, legal and engineering services, prior to the Township accepting petitions.
- B. After meeting with the designated Township official or employee, the property owner(s) may proceed to circulate petitions for the infrastructure project, on a form provided by the Township. The Township Board will only proceed to consider a private infrastructure special assessment district where petitions are circulated and the petitions contain the signatures of the owners of more than 60% of the total frontage of the infrastructure(s) to be improved.
- C. Infrastructure projects pertinent to improvements or repairs are subject to the terms of this policy.
- D. Once petitions are filed, the Township Board will determine, at its discretion, whether to proceed with a private infrastructure project and establish the special assessment district based on the petition received, project schedule, costs, and engineering analysis.
- E. All private infrastructure projects must comply with the Township's Zoning Ordinance and Design and Engineering Standard provisions with respect to private infrastructure. A private maintenance agreement for project proposals may be required by the Township Board as deemed necessary. The Township Board, in consultation with its engineers and representatives of the petitioners, will determine the project scope and design for existing, non-conforming private infrastructures, after consulting industry standards, the Township's Zoning Ordinance, staff and/or engineers. At a minimum, private infrastructure projects must restore infrastructure to the highest standard and quality to which it was previously constructed, improved or maintained.

- F. The Township Board will determine the term of the special assessment district at 10 years. At The Township Board's discretion, projects meeting current design and constructions standards may receive longer than a 10 year assessment than those which do not.
- G. If the Township Board determines to proceed with the project and the special assessment district, the Township Board will determine the method by which parcels within the special assessment district will be assessed for the costs of the project. The Township Board may assess the costs for the project on a front foot basis, per lot basis or a combination thereof in its sole discretion. The Township shall not be obligated to assess costs according to a specific special assessment methodology presented by the property owners in the petitions filed with the Township.
- H. Prior to commencing proceedings to establish a private infrastructure special assessment district, the petitioner(s) or property owner(s) in support of the project shall deposit with the Township the estimated project costs, to be held in escrow by the Township. The Township shall draw on the funds as needed to pay the administrative, publication, legal and engineering and any other costs associated with the proceedings to establish the special assessment district. The Township shall include the costs as a project cost and shall assess those costs to properties within the district.

In the event the special assessment district is not established due to objections from property owners within the district or a determination by the Township Board not to proceed with the district or the project, the Township shall, after providing for payment of all incurred project costs, return any funds remaining in the escrow to the person(s) who paid such funds. If the proceedings to establish the district and/or impose the special assessment are challenged in court or with the Michigan Tax Tribunal, the Township Board may require that additional funds be deposited with the Township prior to the Township's participation in the action to pay for the Township's court costs and legal fees. At the conclusion of the action, the Township shall, after providing for payment of all incurred project costs, return any funds remaining in the escrow to the person(s) who paid such funds.

- I. Plans and estimates of cost for a private infrastructure project in excess of \$15,000 shall be prepared by the Township's engineer. Petitioners or property owners in support of the project shall deposit funds with the Township to be held in escrow to cover all of the estimated project costs. The Township may draw on the escrowed funds as needed to pay the Township's costs associated with the project. The Township shall include the costs as a project cost and shall assess those costs to properties within the district.
- J. The Township Board may determine, at its sole discretion, to finance the costs of a private infrastructure project by issuing special assessment bonds in accordance with Public Act 188 or such other statute as deemed appropriate by the Township Board; or establish and advance funds from another Township fund. In the event the Township

determines to finance a project as described above, the Township Board shall charge interest on unpaid special assessments in accordance with applicable law.

- K. All construction costs (e.g., infrastructure paving) for private infrastructure projects utilizing special assessments and special assessment districts will be selected and awarded by the Township.
- L. The Township Board may determine, in its discretion, whether to conduct any meetings or hearings at special meetings of the Township Board. Any additional costs to conduct special meetings will be included in the cost of the special assessment proceedings and will be assessed to properties within the special assessment district.
- M. The Township Board reserves the right to make other determinations, impose interest and penalties, and proceed in accordance with any and all applicable statutes with respect to infrastructure improvements other than as set forth in this policy.

NEW BUSINESS #5

TYRONE TOWNSHIP
ADMINISTRATIVE PROCEDURES
PURCHASING OF GOODS AND SERVICES

Introduction. The purpose of these procedures is to provide guidance to employees of Tyrone Township (the “Township”) in the acquisition of goods and services in a manner that will:

- Obtain goods and services of the best possible quality and price to meet the needs of the Township;
- Allow the Township to document to its taxpayers that their resources are being used wisely; and
- Ensure compliance with the provisions of state law and applicable Board Policy.

General Principles. The Supervisor is expected to ensure that the funds budgeted for that Township are managed and expended in accordance with Board Policy and that the budget is followed.

Township employees obtaining goods and services with Township funds are expected to act responsibly to obtain those goods and services that meet the Township’s needs at the best possible price. State law imposes requirements that must be followed in order to meet the goals enumerated above. All Township employees may expect to be held accountable for following the procedures listed below for the purchase of goods and services using Township funds.

In evaluating competitive proposals, keep in mind that the best price is not automatically the lowest initial outlay of money, but should also take into account other factors, such as:

- The costs of shipping or pick up,
- Reasonable estimates of supply and maintenance costs over the lifetime of the item purchased,
- The past performance of the proposed supplier,
- Compatibility of the product with existing equipment, and
- Likely resale or salvage value at the end of the item’s useful life.

In evaluating the value of a proposed procurement, the value of the total number of like items purchased will govern. It is not acceptable to obtain multiple smaller invoices for like items from the same vendor over a short period of time in order to avoid competition requirements.

All purchases are subject to board approval, and failure to follow appropriate procedures may result in personal liability.

Minor Purchases. For minor purchases, generally those with a total value of \$500 or less, the time spent in seeking multiple quotes is often more costly than the probable savings. In such cases, the purchaser is expected to use his or her best judgment to obtain the best price, but will ordinarily not be required to produce multiple quotes unless the effort required is small and the potential savings is significant.

Purchases Requiring Informal Competition. For non-minor purchases with a total value less than \$24,999, the purchaser will ordinarily be required to produce evidence of price competition. These may be in several forms, including:

- Written quotations obtained from vendors,
- Catalog prices (taking into account any discounts the Township may be entitled to receive),
- Reliance on bids taken by other governmental or non-profit organizations (such as the State of Michigan, MiDeal), or
- Price quotations obtained by telephone with proper documentation. Proper documentation should include:
 - The vendor contacted and person spoken to,
 - The exact item offered including brand and model,
 - The telephone number called, and
 - The date of the conversation.

The person making the purchase should obtain enough quotations to satisfy himself/herself that the best price has been identified. Ordinarily, three quotations from major suppliers should be sufficient.

Purchases Requiring Formal Competition. For purchases in excess of \$25,000, formal competition is required.

In many cases, the State of Michigan or other entities may solicit bids on behalf of a number of Townships or other governmental units. If such a solicitation meets the Township's needs, it may be relied upon for price competition. Otherwise, Township staff must solicit bids.

A written request for bids is prepared and published in a form likely to reach the greatest number of potential offers. The bid request contains the complete specifications for the goods or services being purchased, including payment terms and delivery and warranty requirements. The bid request specifies the form in which the offer must be submitted, the address to which the offers must be submitted, the deadline for submission, and the time and place at which the bids will be publicly opened and read. In addition, there is standard language that must be included in most bid requests. Contact

Following bid analysis, a recommendation will be made to the Supervisor, Clerk and Treasurer. If the Supervisor, Clerk and Treasurer approve, the recommendation will be forwarded to the Township Board for their approval.

Emergency Purchases. If goods or services are needed during the emergency, normal purchasing requirements can be waived assuming that compliance was not possible and the Supervisor acted in good faith.

An emergency is a situation where immediate action is required in order to protect life and limb or to preserve valuable property. (Fire and flood would be clear examples of emergencies). Board approval, where needed, will be sought after the fact as soon as it is reasonably possible.

Special Cases.

Professional Services. Professional services, such as architectural, engineering, legal, consulting, and auditing services, normally do not lend themselves to direct price competition. Often such services are a very small portion of the total cost of a project, and quality may be much more important than price.

When soliciting quotations for such services, the solicitations should be structured in such a way as to measure, as objectively as possible, the quality of the competing proposals. A history of performance in providing the services needed and the experience and professional qualifications of the provider are among the factors that should be taken into account in preparing a recommendation to engage professional services.

Normally, a Professional Services Contract is written controlling the delivery of such services and their payment. This contract will normally be subject to approval by the Board regardless of the amount of money involved.

Governmental Services. Normally, goods and services obtained from other governmental units do not require competitive proposals, regardless of the amount of money involved.

NEW BUSINESS #6

NEW BUSINESS #7

Terri Medor

From: Ross Nicholson
Sent: Thursday, June 13, 2019 10:10 AM
To: Terri Medor
Cc: Mike Cunningham
Subject: BOARD AGENDA REQUEST
Attachments: CIDER MILL CROSSING ENTRANCE PLANS_5-29-19.pdf

Importance: High

Hi Terri,

Cider Mill Crossings has made changes to their plans for State compliance purposes. Mike has requested that this amendment to the consent judgement be included on the next available Board agenda. Please include the correspondence below and the attached plans in the packets.

Thank you!

Ross Nicholson

Planning & Zoning Administrator

Tyrone Township
10408 Center Rd.
Fenton, MI 48430
phone: (810) 629-8631
fax: (810) 629-0047



www.tyronetownship.us

Notice: This email, including any attachments, is covered by Electronic Communication Privacy Act, 18 U.S.C. 2510-2521, is confidential and may be legally privileged. If you are not the intended recipient, you are hereby notified that any retention, distribution or copying of this communication is strictly prohibited. Please reply to the sender if you have received this message in error and destroy all copies of the original message.

From: mdiffin@diffin-umlor.com <mdiffin@diffin-umlor.com>
Sent: Thursday, June 13, 2019 9:48 AM
To: Ross Nicholson <rnicholson@tyronetownship.us>; supervisor@tyronetownship.com
Cc: Len Shember <LShember@suncommunities.com>; Nick Sytsma <nsytsma@atwell-group.com>
Subject: FW: Cider Mill Crossings Old US-23 Secondary Entrance

Mike & Ross,

Please find attached the most up to date set of plans for the Cider Mill Crossings secondary entrance. The State came up with a new rule that states that mobile park entrances shall have a left and right turn lanes. We've widened the entrance a little to meet the Livingston County "Typical Boulevard Entrance" detail. The County has already reviewed and approved these revisions (see email chain below). Please let us know if this change needs to be rerouted through the Planning Commission and/or Township Board for reapproval or if this can be done internally.

Thanks

Matthew A. Diffin, PE

Principal

Diffin-Umlor and Associates



49287 West Road

Wixom, MI 48393

Office: (248) 773-7656

Fax: (866) 690-4307

Cell: (248) 943-8244

e-mail: mdiffin@diffin-umlor.com

From: Kim Hiller <khiller@livingstonroads.org>

Sent: Wednesday, June 5, 2019 1:23 PM

To: mdiffin@diffin-umlor.com

Cc: Len Shember <LShember@suncommunities.com>; Nick Sytsma <nsytsma@atwell-group.com>

Subject: RE: Cider Mill Crossings Old US-23 Secondary Entrance

Matthew,

I have reviewed the revised plans and have determined they are in compliance with our specifications. I have prepared a new permit for the contractor's signature. Please let the contractor know the permit is ready. Our permits office is open Monday-Friday from 8:00 AM to 5:00 PM.

Thank you,

Kim Hiller, P.E.

Utilities and Permits Engineer

Livingston County Road Commission

3535 Grand Oaks Drive

Howell, MI 48843

Ph. (517) 546-4250

khiller@livingstonroads.org

From: mdiffin@diffin-umlor.com <mdiffin@diffin-umlor.com>

Sent: Monday, June 03, 2019 10:02 AM

To: Kim Hiller <khiller@livingstonroads.org>

Cc: Len Shember <LShember@suncommunities.com>; Nick Sytsma <nsytsma@atwell-group.com>

Subject: Cider Mill Crossings Old US-23 Secondary Entrance

Kim,

Sorry we had to modify these plans again. The State came up with a new rule that states that mobile park entrances shall have a left and right turn lanes. We've widened the entrance a little to meet the Livingston County "Typical Boulevard Entrance" detail. I put to new sets of this plan in the mail when you get a chance if you could please review and let us know if this is acceptable.

Thanks

Matthew A. Diffin, PE

Principal

Diffin-Umlor and Associates



49287 West Road

Wixom, MI 48393

Office: (248) 773-7656

Fax: (866) 690-4307

Cell: (248) 943-8244

e-mail: mdiffin@diffin-umlor.com

OLD US-23 \ PRIVATE ROAD ENTRANCE PLANS

CIDER MILL CROSSINGS

MANUFACTURE HOUSING COMMUNITY
 TYRONE TOWNSHIP, LIVINGSTON COUNTY, MICHIGAN
 SECTION 32 , TOWN 4 NORTH, RANGE 6 EAST

CONSULTANT:
Diffin-Umlor & ASSOCIATES
 Civil Engineering • Surveying • Landscaping • Construction Services
 49287 West Road
 Wixom, Michigan 48393
 Tel. (248) 437-7803
 Fax. (866) 690-4307
 CONTACT:
 MATTHEW DIFFIN, P.E.

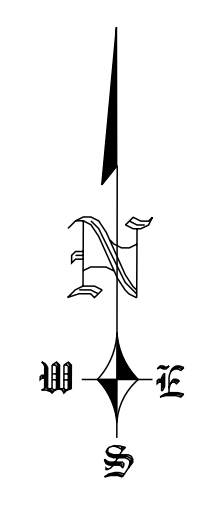

PLAN INDEX

1. COVER SHEET	RD-1
2. REMOVAL PLAN & ROAD WIDENING PLAN	RD-2
3. GRADING & STRIPING PLAN	RD-3
4. LANDSCAPING & LIGHTING PLAN	RD-4
5. DETAIL SHEET	RD-5

CONTACT INFORMATION

Livingston County Drain Commissioner
 Mr. Brian Jonckheere, Drain Commissioner
 Mr. Kenneth E. Recker, P.E. Chief Deputy
 2300 E. Grand River Ave.
 Howell, MI 48843
 Telephone: 517-546-0040
 Fax Phone: 517-545-9658

Tyrone Township Hall
 Supervisor: Mike Cunningham
 10408 Center Road
 Fenton, MI 48830
 Telephone: 810-629-8631
 Fax Phone: 810-629-0047

Livingston County Road Commission
 Mr. Steven J. Wasylk, P.E.
 Utilities & Permits Engineer
 3535 Grand Oaks Drive
 Howell, MI 48843
 Telephone: 517-546-4250
 Fax Phone: 517-546-9628

Livingston County Health Department
 Mr. Don W. Hayduk, M.S.
 Environmental Sanitarian
 2300 East Grand River
 Howell, MI 48843-7579
 Telephone: (517) 546-9858 Ext. 433
 Fax Phone: (517) 546-9853

Enbridge (U.S.) Inc.
 Operating the Enbridge Energy and
 Vector Pipeline System
 Mr. Eric Weaver-Senior Right-Of-Way Agent
 3751 Mackinaw Road
 Bay City, MI 48706-9433
 Telephone: (989) 684-0160 Ext. 28
 Email: eric.werner@enbridge.com
 Mr. Brandon Wagner-Crossing Coordinator
 Telephone: (269) 986-5742
 Email: brandon.wagner@enbridge.com

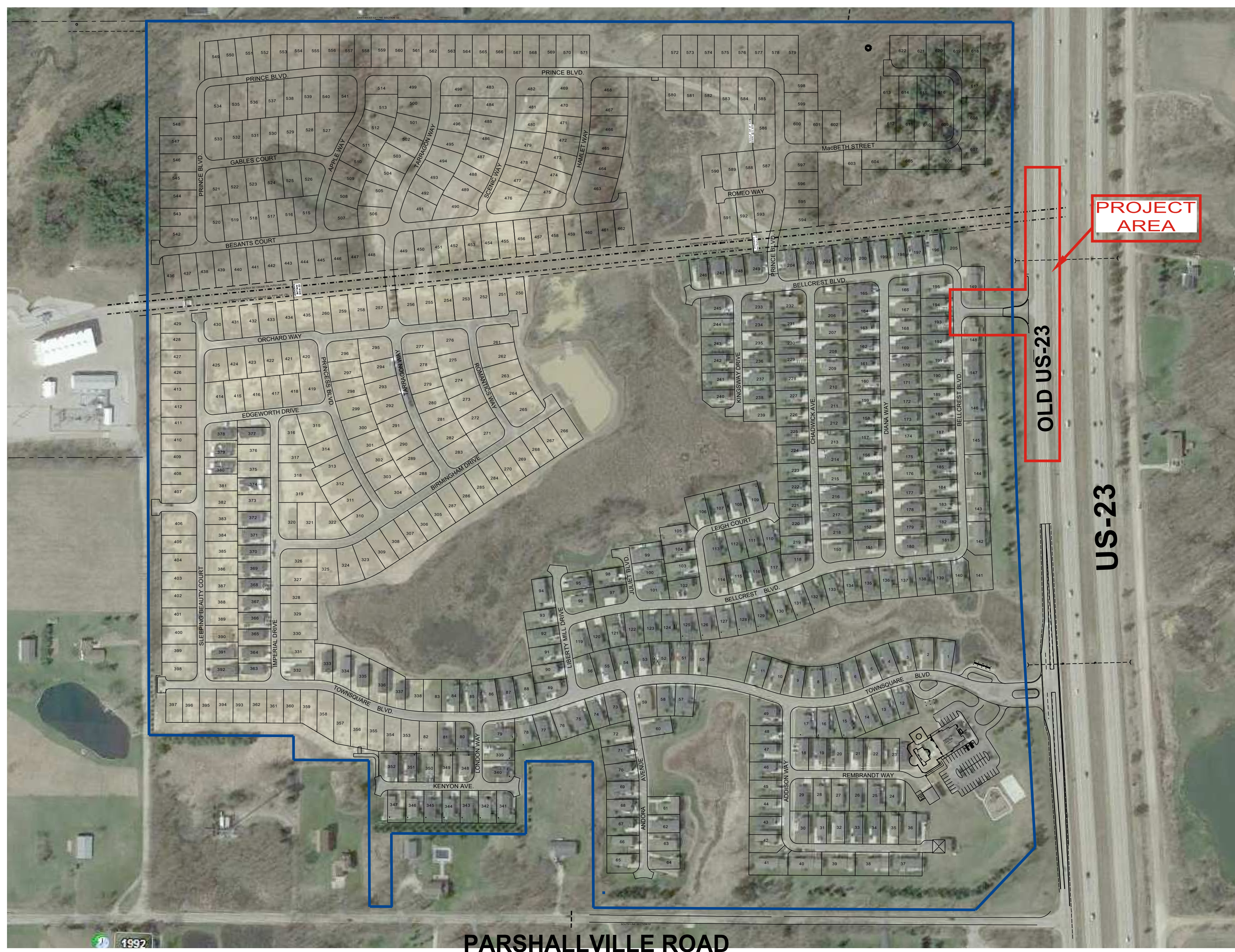

PROJECT AREA

OLD US-23

US-23

PARSHALLVILLE ROAD

ALL SEDIMENTATION PONDS SHALL BE EXCAVATED, TOP SOILED, SEEDED, STRAW MULCHED, AND TACKED PRIOR TO THE START OF THE MASSIVE EARTH DISRUPTION.

ALL ONSITE ROADWAYS, DRAINAGE, WATER WATER SYSTEMS, AND PORTABLE WATER SYSTEMS ARE PRIVATLEY OWNED AND MAINTAINED BY THE DEVELOPMENT.

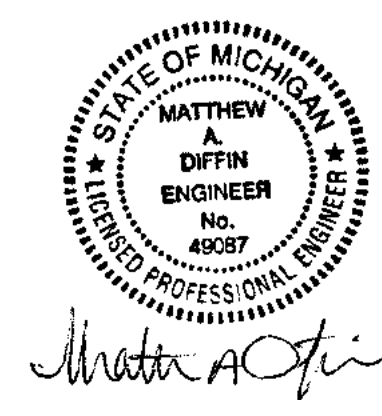

72 HOURS
 (3 WORKING DAYS)
**BEFORE YOU DIG
 CALL MISS DIG**
 800-482-7171
 (TOLL FREE)

REVISIONS:

- REVISED PER LIVINGSTON COUNTY ROAD COMMISSION 6-31-18 REVIEW
- REVISED PER TWP, PLANNER'S 9-10-18 REVIEW
- REVISED PER TWP. 2-13-19 MEETING COMMENTS
- REVISED PER LARA 5-23-19 REVIEW COMMENTS

SCALE: 1" = 200'

LAYOUT COORD: MAD

PLANNING MGR. MAD

DRAWING BY: MAD

DATE: MAY 29, 2019

JOB NUMBER: 991214

TITLE: COVER SHEET

SHEET NUMBER:
RD-1
 SHEETS 1 OF 5

COMMENTS:

LEGAL DESCRIPTION:
 Commencing at the South 1/4 corner of Section 32, T.4N, R.6E., Tyrone Township, Livingston County, Michigan; thence North 00 degrees 12 minutes 40 seconds West 539.52 feet along the North-South 1/4 line to the Point of Beginning; thence continuing North 00 degrees 12 minutes 40 seconds West (M) 2124.94 feet (M) North 00 degrees 14 minutes 21 seconds West (R) 2123.63 feet (R) along the North-South 1/4 line of said Section to the center of said section; thence South 89 degrees 56 minutes 15 seconds East (R) 2657.16 feet (R) South 89 degrees 56 minutes 23 seconds East (M) 2657.17 feet (M) along the East-West 1/4 line of said Section to the East 1/4 corner of said section; thence South 00 degrees 08 minutes 51 seconds West (M) 2676.29 feet (M) South 00 degrees 07 minutes 19 seconds West (R) 2676.32 feet (R) along the East line of said section to the Southeast corner of said section; thence North 89 degrees 40 minutes 49 seconds West 1320.44 feet along the South line of said section; thence North 00 degrees 14 minutes 21 seconds West 468.02 feet; thence North 89 degrees 40 minutes 49 seconds West 200.01 feet; thence South 00 degrees 14 minutes 21 seconds East 217.01 feet; thence North 89 degrees 40 minutes 49 seconds East 251.01 feet; thence North 89 degrees 40 minutes 49 seconds West 66.00 feet along the South line of said section; thence North 00 degrees 14 minutes 21 seconds West 468.02 feet; thence North 89 degrees 40 minutes 49 seconds West 224.01 feet; thence North 00 degrees 12 minutes 40 seconds West (M) 71.50 feet (M) North 00 degrees 14 minutes 21 seconds West (R) 71.50 feet (R); thence North 89 degrees 40 minutes 49 seconds West 430.01 feet to the Point of Beginning, containing 150.17 acres more or less and subject to easements, restrictions, reservations, leases and agreements of record if any.

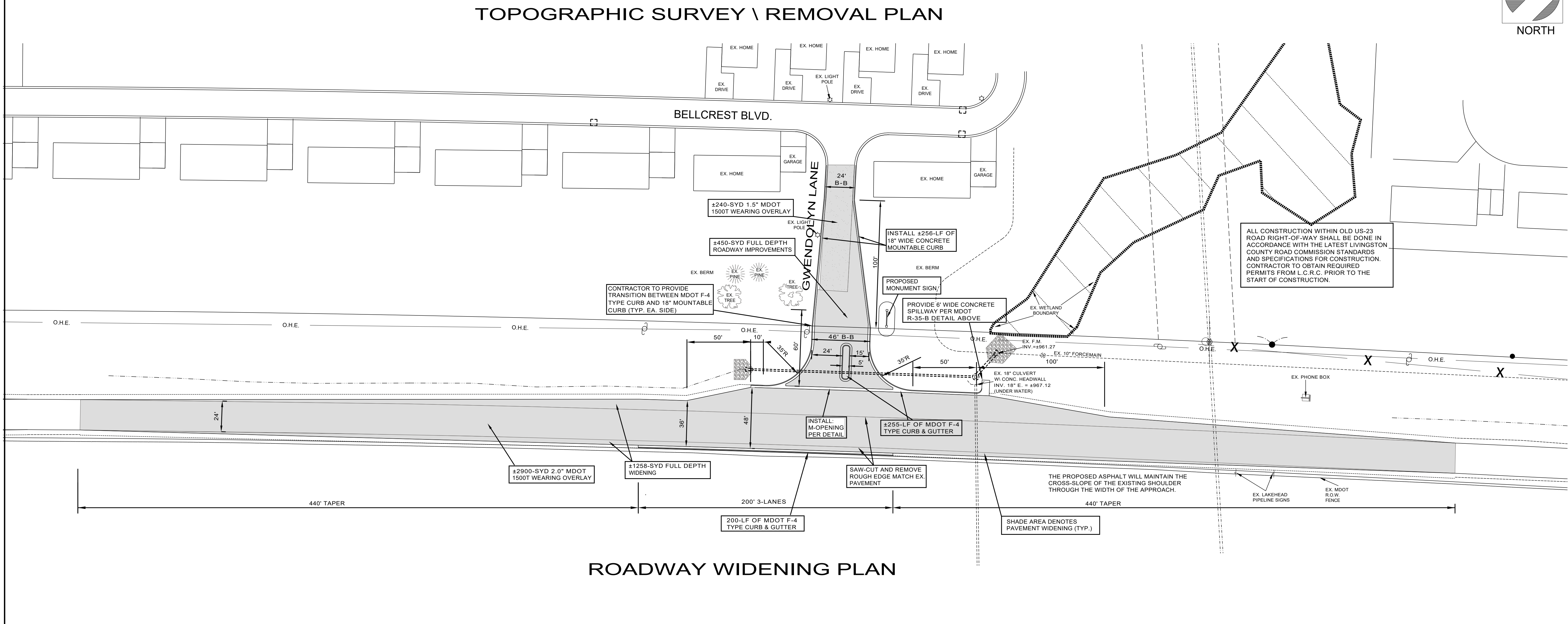
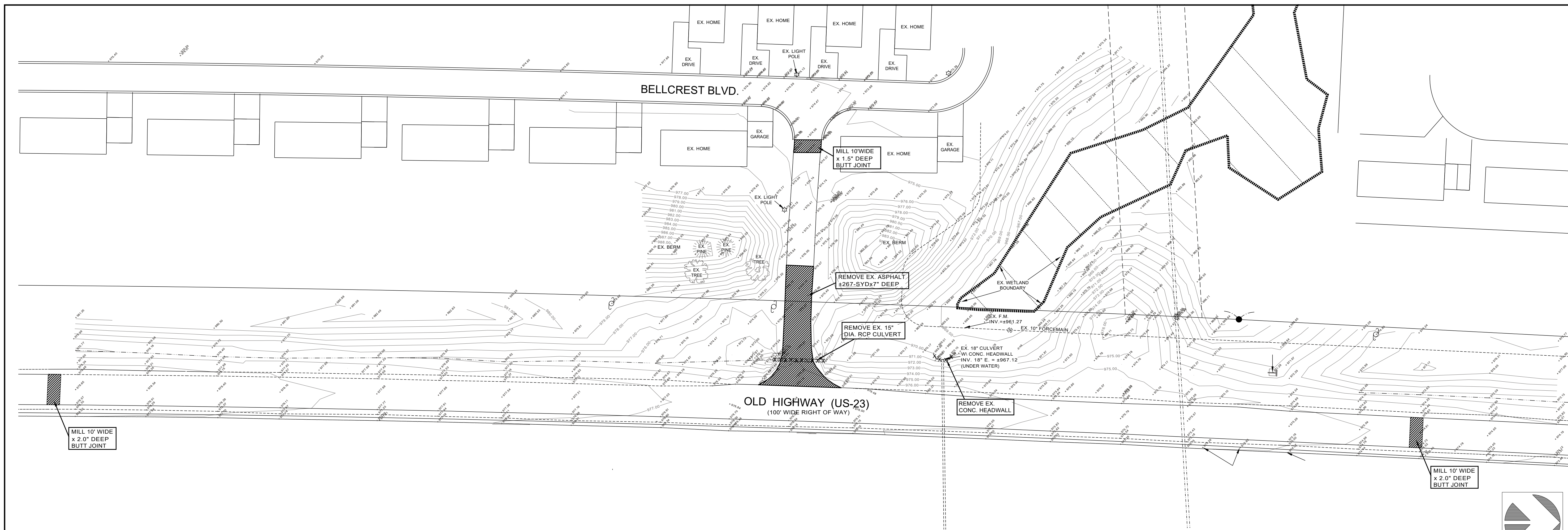

CONSULTANT:
Diffin-Umlor & Associates
 Civil Engineering • Surveying • Landscaping • Construction Services
 49287 West Road
 Wixom, Michigan 48393
 Tel. (248) 437-7803
 Fax. (866) 690-4307
 CONTACT:
 MATTHEW DIFFIN, P.E.

DRAWING ALTERATION
 IT IS A VIOLATION OF LAW FOR ANY PERSON, UNLESS ACTING UNDER THE DIRECTION OF A LICENSED ARCHITECT, PROFESSIONAL ENGINEER, LANDSCAPE ARCHITECT, OR LAND SURVEYOR TO ALTER ANY ITEM ON THIS DOCUMENT IN ANY WAY.
 ANY LICENSEE WHO ALTERS THIS DOCUMENT IS REQUIRED BY LAW TO AFFIX HIS OR HER SEAL AND THE NOTATION "ALTERED BY" FOLLOWED BY HIS OR HER SIGNATURE AND SPECIFIC DESCRIPTION OF THE ALTERATIONS.

SEAL:

SUN
SUN COMMUNITIES INC.
 27777 FRANKLIN ROAD SUITE 200
 SOUTHFIELD, MICHIGAN 48034
 Phone: (248) 208-2500
 Fax: (248) 208-2640
MR. LEONARD SHEMBER
 VICE PRESIDENT
 OF CONSTRUCTION SERVICES

CIDER MILL CROSSINGS
 A PLANNED UNIT HOUSING COMMUNITY
 TYRONETOWNSHIP, LIVINGSTON COUNTY, MI

REVISIONS:
 REVISED PER LIVINGSTON COUNTY ROAD COMMISSION 6-31-18 REVIEW
 REVISED PER TWP. PLANNER'S 9-10-18 REVIEW
 REVISED PER TWP. 2-13-19 MEETING COMMENTS
 REVISED PER LARA 5-23-19 REVIEW COMMENTS

SCALE: 1" = 40'
 LAYOUT COORD: MAD
 PLANNING MGR: MAD
 DRAWING BY: MAD
 DATE: MAY 29, 2019
 JOB NUMBER: 991214
 TITLE: ROADWAY DETAILS

SHEET NUMBER:
RD-2
 SHEETS 2 OF 5
 COMMENTS:

DRAWING ALTERATION
 IT IS A VIOLATION OF LAW FOR ANY PERSON, UNLESS ACTING UNDER THE DIRECTION OF A LICENSED ARCHITECT, PROFESSIONAL ENGINEER, LANDSCAPE ARCHITECT, OR LAND SURVEYOR TO ALTER ANY ITEM ON THIS DOCUMENT IN ANY WAY.
 ANY LICENSEE WHO ALTERS THIS DOCUMENT IS REQUIRED BY LAW TO AFFIX HIS OR HER SEAL AND THE NOTATION "ALTERED BY" FOLLOWED BY HIS OR HER SIGNATURE AND SPECIFIC DESCRIPTION OF THE ALTERATIONS.

SEAL:

SUN
SUN COMMUNITIES INC.
 27777 FRANKLIN ROAD SUITE 200
 SOUTHFIELD, MICHIGAN 48034
 Phone: (248) 208-2500
 Fax: (248) 208-2640
MR. LEONARD SEMBER
 VICE PRESIDENT
 OF CONSTRUCTION SERVICES
CIDER MILL CROSSINGS
 A PLANNED UNIT HOUSING COMMUNITY
 TYRONETOWNSHIP, LIVINGSTON COUNTY, MI

REVISIONS:
 REVISED PER LIVINGSTON COUNTY ROAD COMMISSION 6-31-18 REVIEW
 REVISED PER TWP. PLANNER'S 9-10-18 REVIEW
 REVISED PER TWP. 2-13-19 MEETING COMMENTS
 REVISED PER LARA 5-23-19 REVIEW COMMENTS

SCALE: 1" = 40'
 LAYOUT COORD: MAD
 PLANNING MGR. MAD
 DRAWING BY: MAD
 DATE: MAY 29, 2019
 JOB NUMBER: 991214

TITLE:
**OLD US-23 \ PRIVATE ROADWAY
 GRADING \ STRIPING PLAN**
 SHEET NUMBER:
**RD-3
 SHEET 3 OF 5**

COMMENTS:

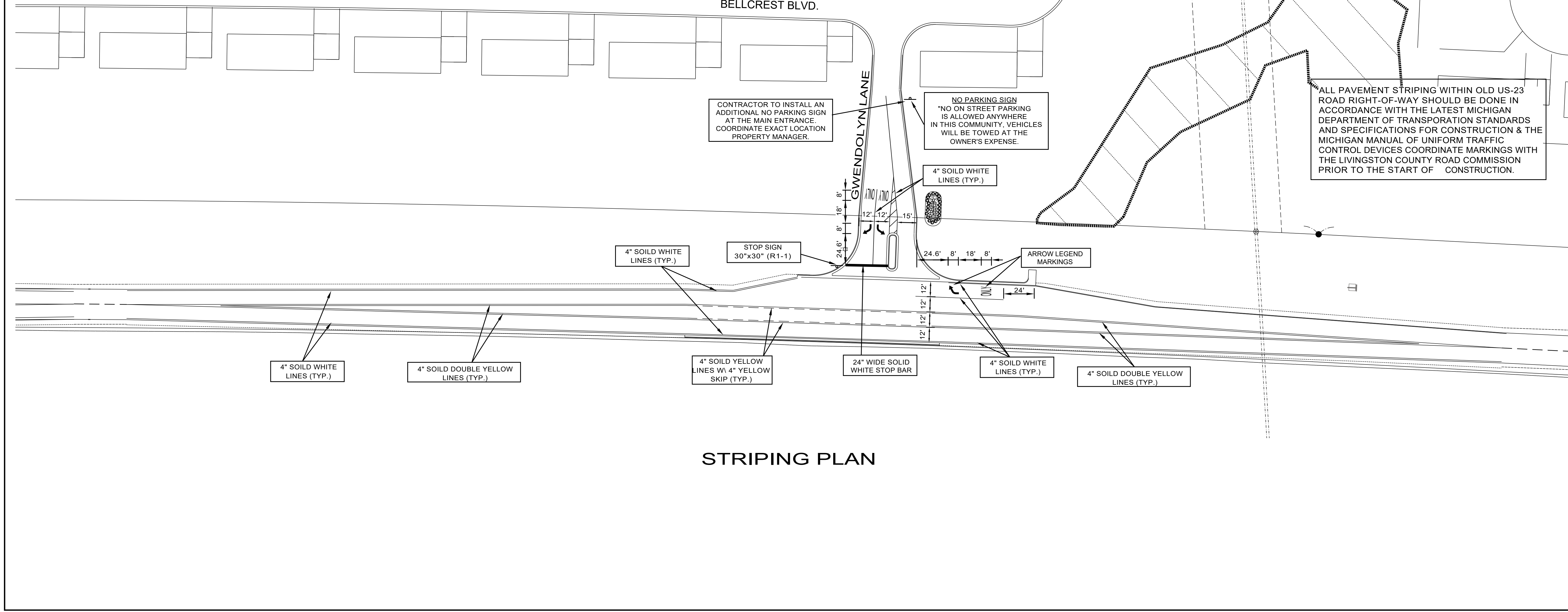
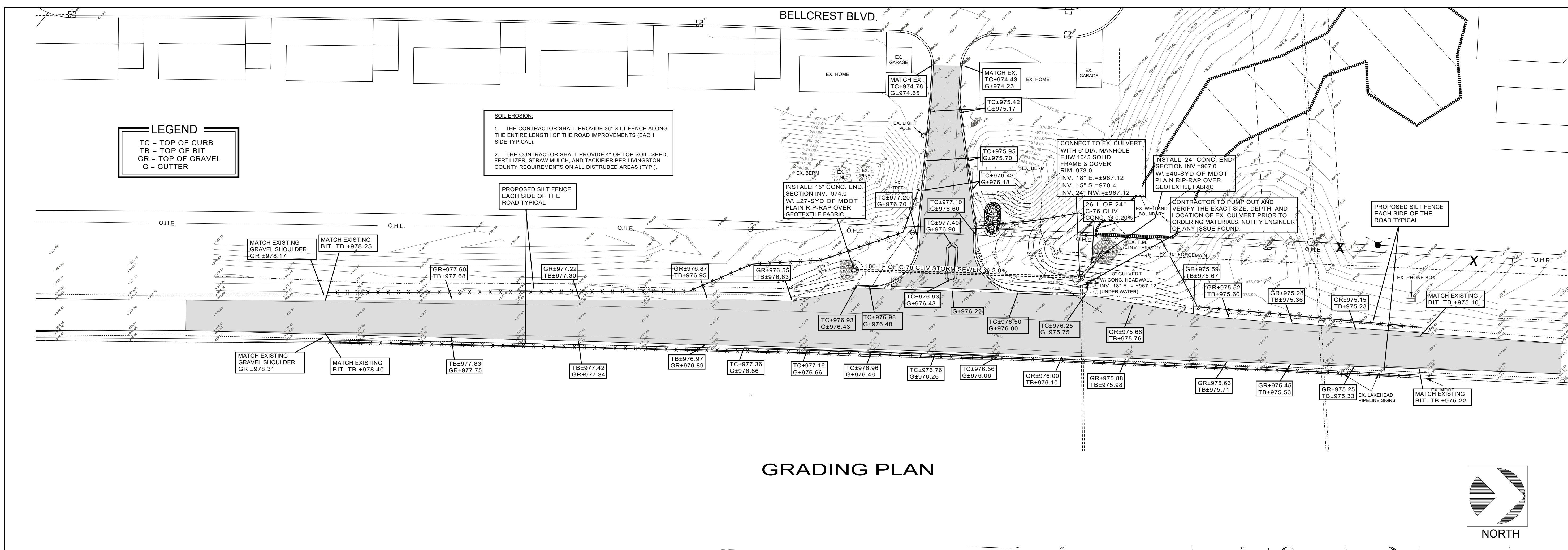

PLANTING NOTES

- LOAM USED IN PLANTING BEDS SHALL BE UNIFORM IN COMPOSITION, FREE OF STONES LARGER THAN 1" AND SHALL NOT CONTAIN TOXIC SUBSTANCES HARMFUL TO PLANT GROWTH.
- CREATE A PLANTING MIX COMPRISED OF 2/3 SCREENED LOAM AND 1/3 PEAT MOSS OR LEAF COMPOST. AMEND WITH 'PLANTONE' ORGANIC FERTILIZER (NO PHOSPHORUS), OR EQUAL, AT THE RATE RECOMMENDED BY MANUFACTURER.
- THE CONTRACTOR SHALL SUPPLY ALL PLANT MATERIALS IN QUANTITIES SUFFICIENT TO COMPLETE THE PLANTING SHOWN ON THIS DRAWING.
- ALL PLANT MATERIALS SHALL CONFORM TO THE GUIDELINES ESTABLISHED BY THE AMERICAN STANDARD FOR NURSERY STOCK PUBLISHED BY THE AMERICAN ASSOCIATION OF NURSERYMEN, INC.
- PLANT PITS SHALL BE DUG TWICE THE WIDTH OF THE ROOTBALL. PLANT PITS AND PLANTING BEDS SHALL BE BACKFILLED WITH THE AMENDED PLANTING MIX IN LIFTS TO AVOID AIR POCKETS IN BACKFILL.
- ALL PLANT MATERIAL TO BE SET PLUMB, AND TO BEAR NATURAL RELATIONSHIP WITH FINISHED GRADE.
- ALL BIODEGRADABLE BURLAP SHALL BE UNTIED AND PULLED DOWN ON THE BALL. WIRE BASKETS AND OTHER NON BIODEGRADABLE MATERIALS ATTACHED TO PLANTS SHALL BE REMOVED PRIOR TO PLANTING. CARE SHALL BE TAKEN NOT TO BREAK OR DISTURB ROOTBALL OF PLANTS.
- ALL PLANTS SHALL BE WATERED IMMEDIATELY AFTER PLANTING. TEMP. WATERING BAGS SHALL BE INSTALLED ON ALL TREES.
- 3" OF COMPOSTED PINE BARK MULCH SHALL BE SPREAD OVER ALL PLANT BEDS.
- THE CONTRACTOR SHALL MAINTAIN ALL PLANTS FOR 90 DAYS AFTER THE COMPLETION OF PLANT INSTALLATION. MAINTENANCE SHALL CONSIST OF KEEPING ALL PLANTS IN A HEALTHY GROWING CONDITION.
- PLANTS SHALL BE GUARANTEED FOR A PERIOD OF 1 YEAR AFTER ACCEPTANCE OF THE PROJECT AND SHALL BE ALIVE AND IN SATISFACTORY GROWTH AT THE END OF THE GUARANTEE PERIOD. THE CONTRACTOR SHALL BE RESPONSIBLE TO REMOVE ALL FAILING PLANT MATERIALS, AND REPLACE THEM WITH THE SAME KIND AND SIZE OF MATERIAL AS SPECIFIED IN THE PLANT LIST, WITH THE SAME GUARANTEE AS INITIAL PLANTING.
- CONTRACTOR SHALL LOCATE AND VERIFY ALL EXISTING UTILITY LINES PRIOR TO PLANTING AND SHALL REPORT ANY CONFLICTS TO THE OWNER.
- ALL PLANTING BEDS AND GREENBELT AREAS SHALL RECEIVE SIX INCHES (6") OF SCREENED TOPSOIL, MEASURED AFTER COMPACTION, PRIOR TO INSTALLATION OF PLANTS, SEEDING, OR SODDING.
- ALL LANDSCAPE ISLANDS SHALL BE FILLED SUCH THAT THEY ARE CROWNED IN THE MIDDLE TO PROVIDE POSITIVE DRAINAGE AND TO PREVENT POOLING WITHIN THE LANDSCAPED AREA (TYP.)
- ALL LAWN AND LANDSCAPE AREAS SHALL BE IRRIGATED, EXCLUDING THE WETLANDS AREAS.
- ALL GROUND MOUNTED UTILITIES SHALL BE FULLY SCREENED WITH LANDSCAPE PLANTINGS.

KEY	QUAN.	SIZE	BOTANICAL NAME	COMMON NAME
AR	6	2.5" Cal.	Acer rubrum 'Franksred'	'Red Sunset' Maple
AS	8	2"	Amelanchier spp.	Serviceberry
PN	2	8"	Pinus nigra	Austrian Pine
PP	10	8"	Picea pungens glauca	Colorado Blue Spruce
HA	4	24" HT.	Hydrangea 'Endless Summer'	Hydrangea
HS	18	1 Gal.	Hemerocallis 'Stella de Oro'	Daylily
JW	21	1 Gal.	Juniperus Horizontalis 'Wiltonii'	Blue Rug Juniper



EXISTING SIGN PHOTO

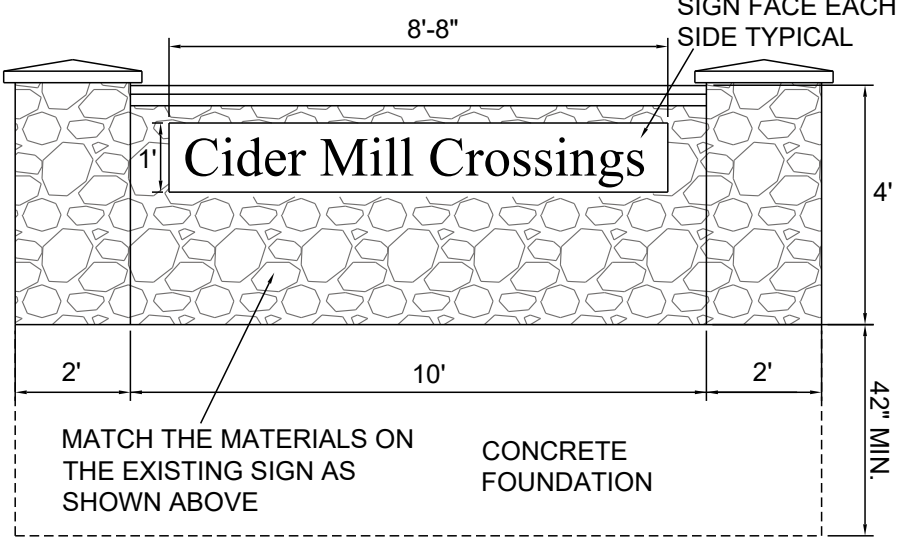

PROPOSED SIGN LAYOUT

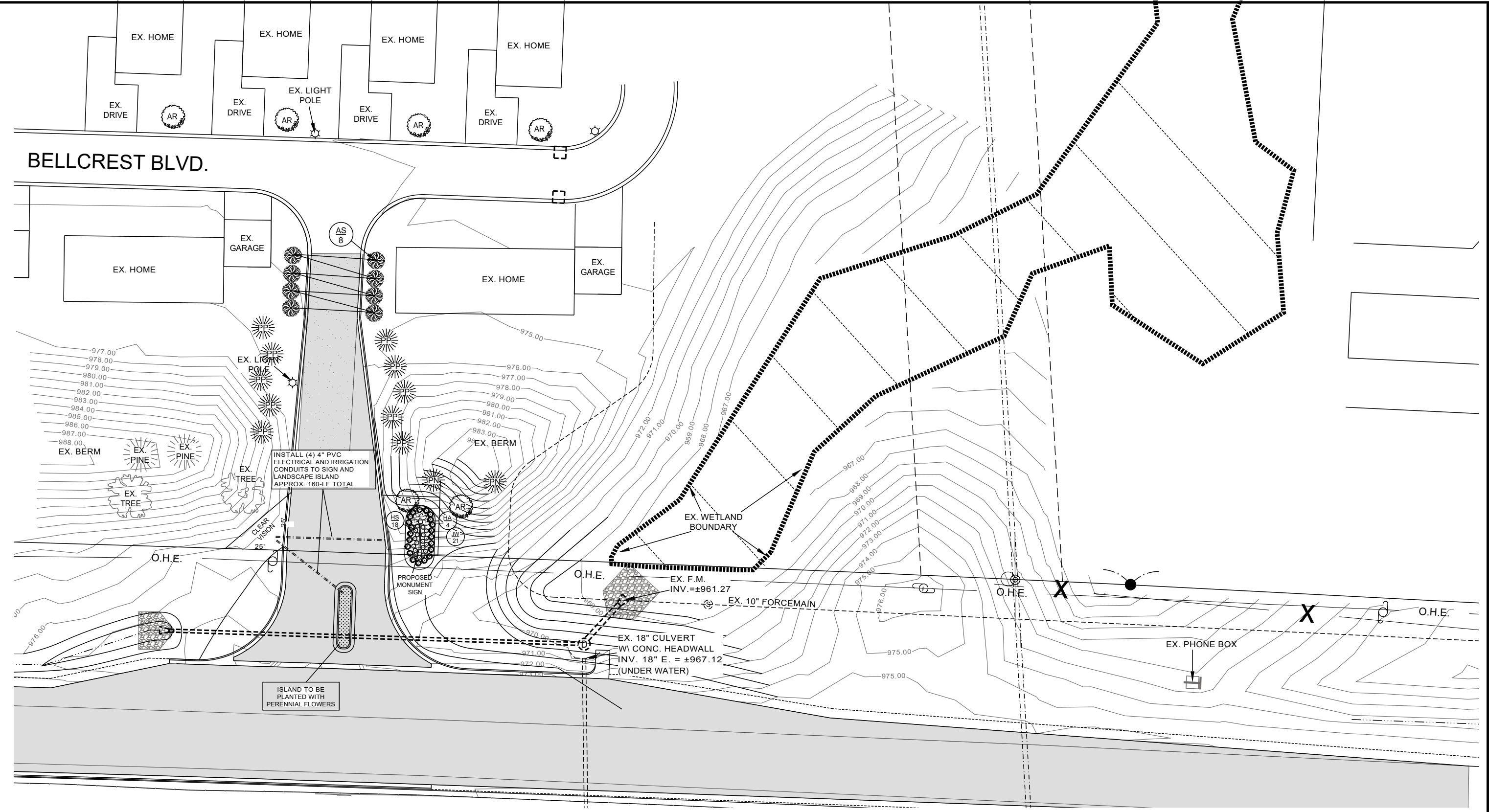

Seeding, Fertilizer and Mulch Bare Ground Ratio

Top-Soil 3" in depth
 Grass Seed 217.84 lbs per acre
 Fertilizer 150 lbs per acre
 Straw Mulch 3" in depth 1 1/2 to 2 tons per acre (All mulching must have a tie down-asphalt tackifier, net binding, etc.)

LANDSCAPE PLAN

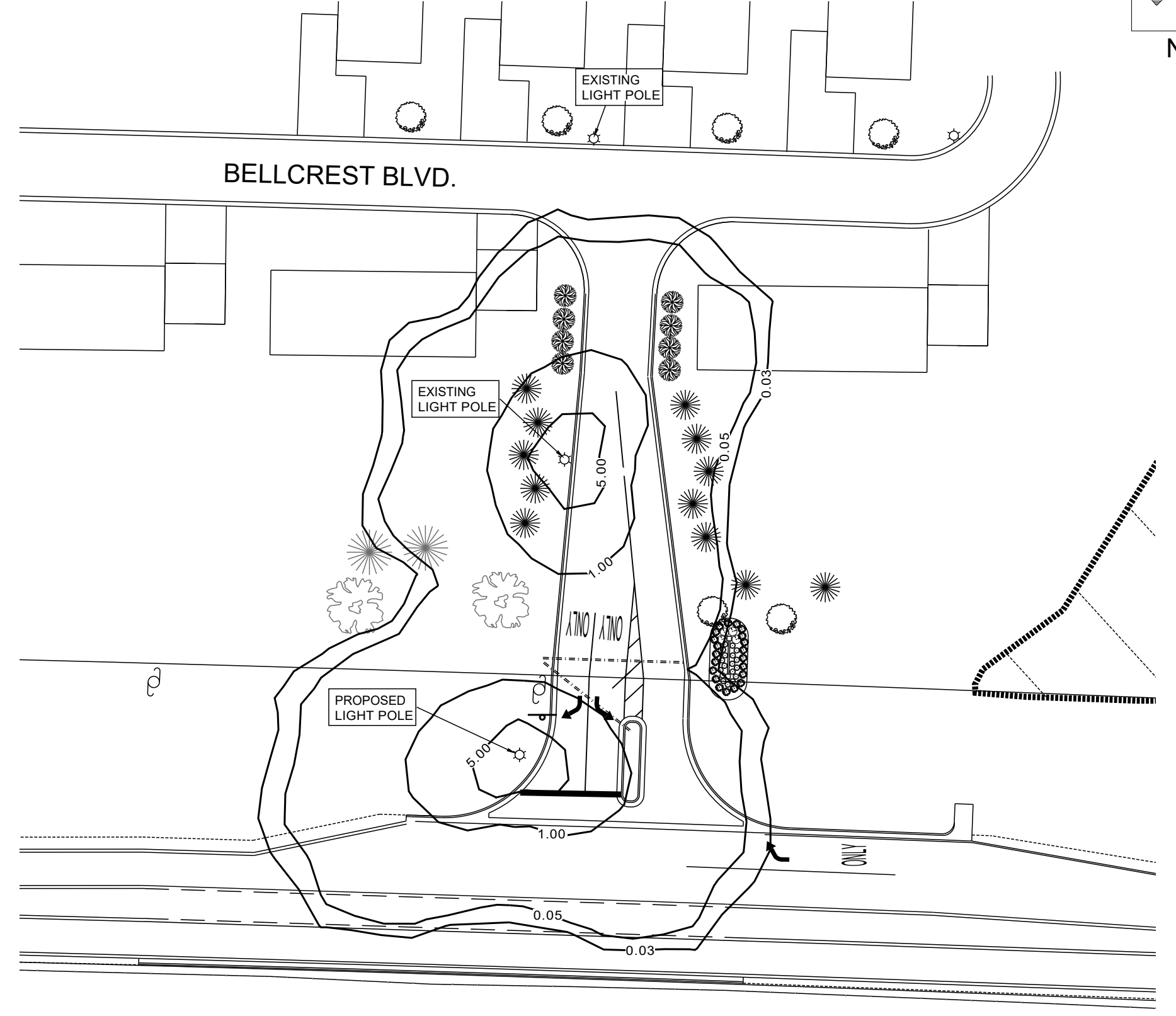
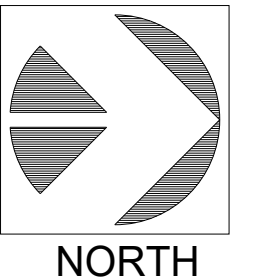

LIGHTING PHOTOMETRIC PLAN

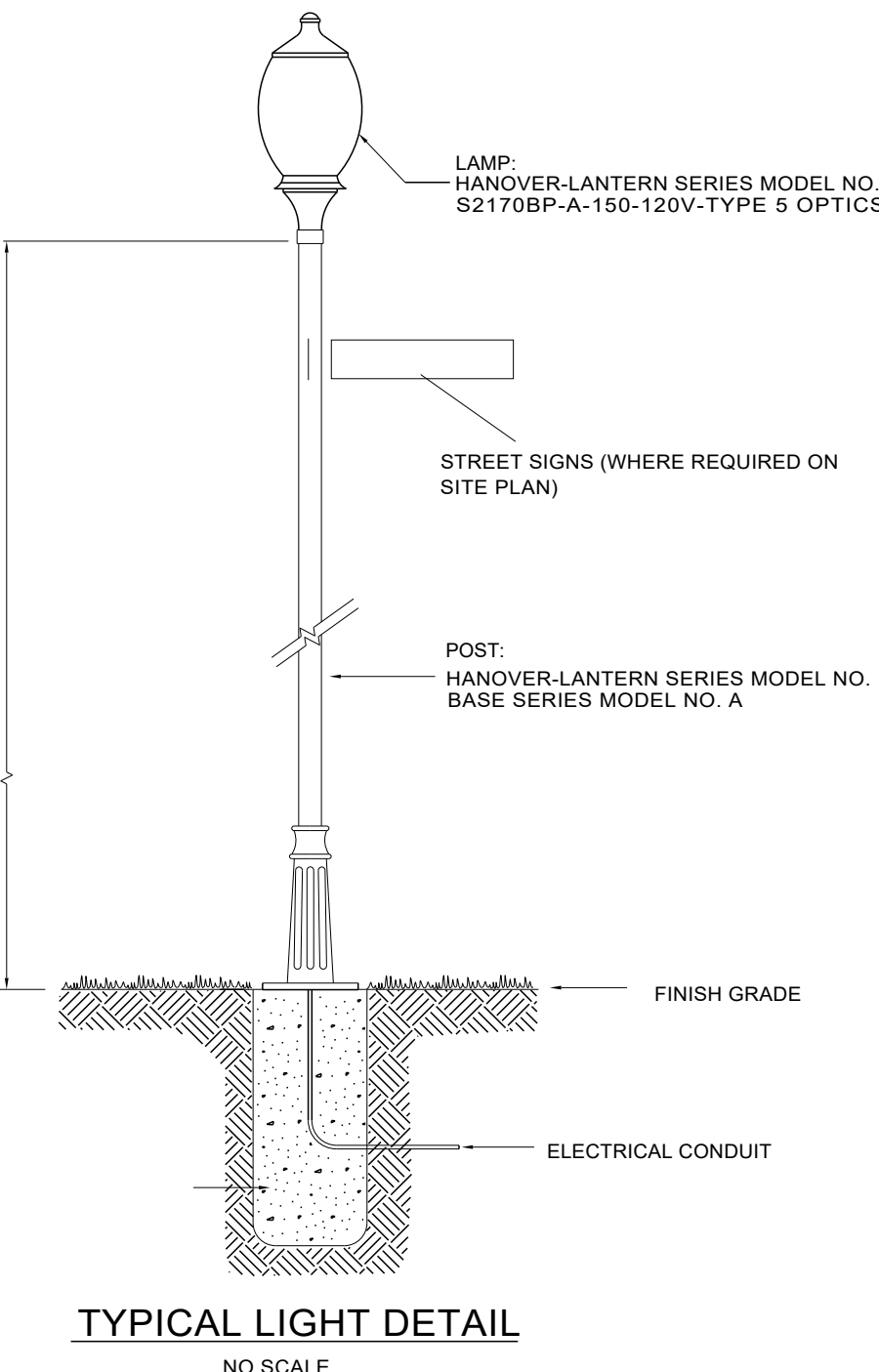

TYPICAL LIGHT DETAIL

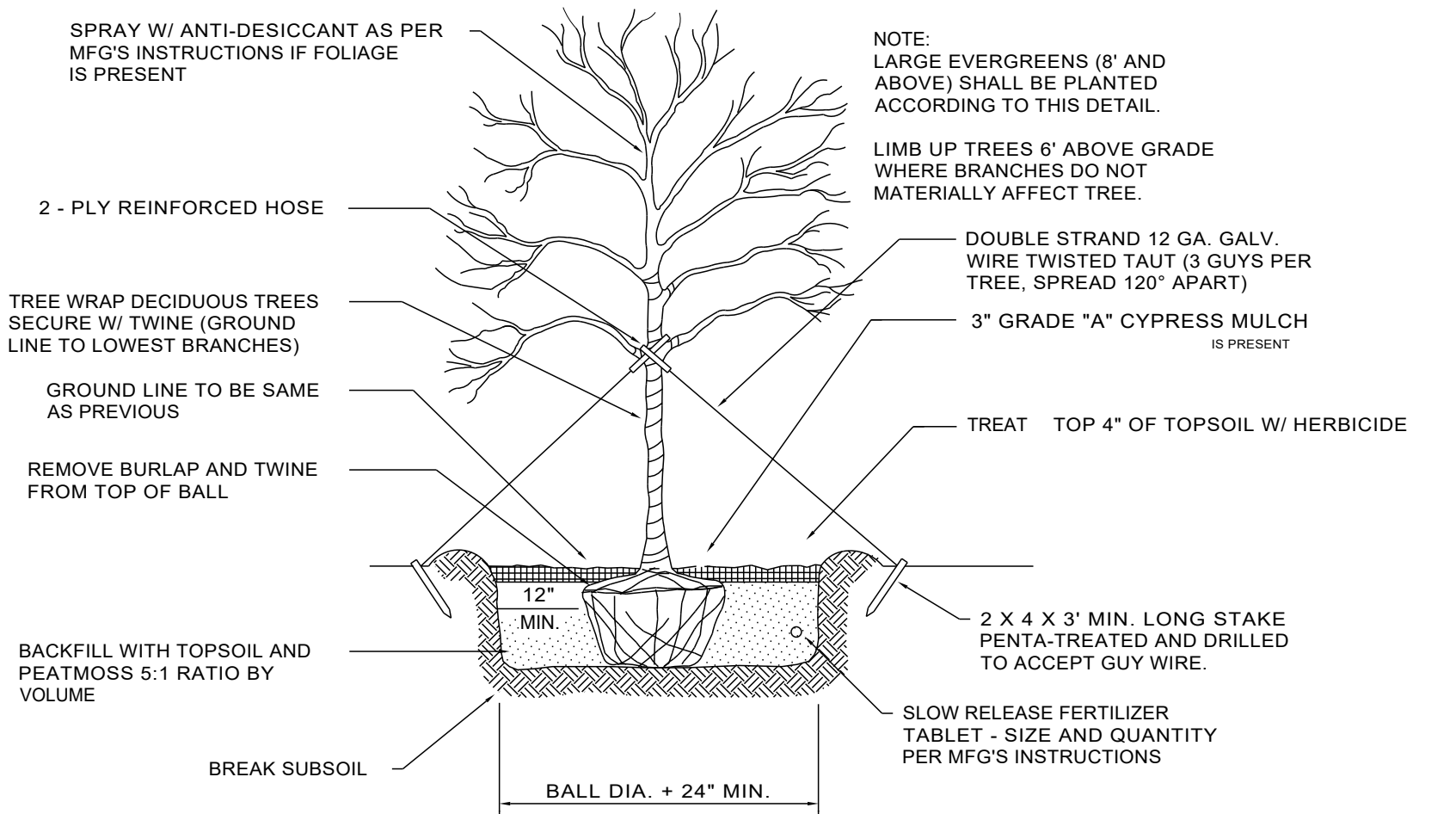

PLANTING & STAKING DETAIL

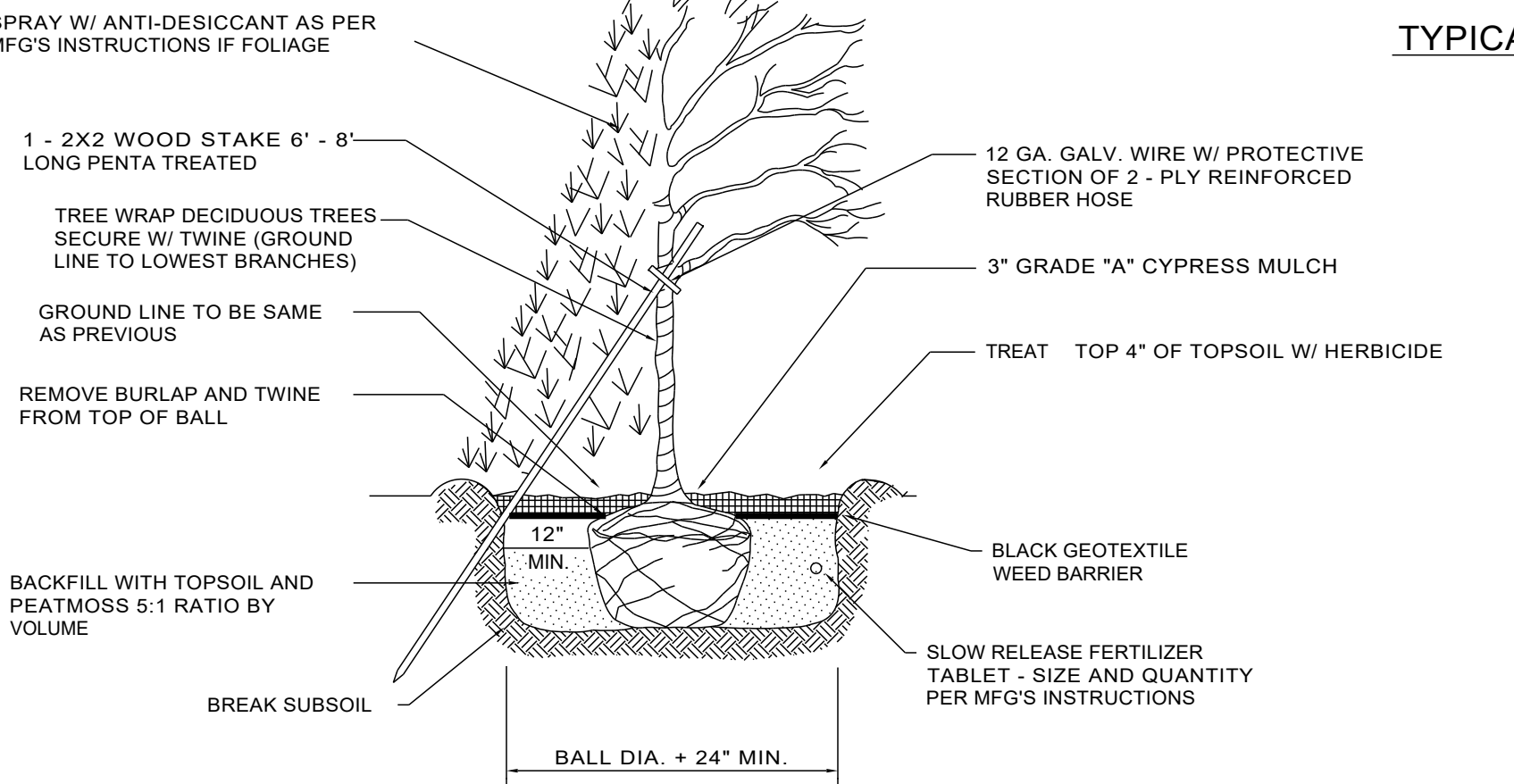

PLANTING & STAKING DETAIL

CONSULTANT:
Diffin-Umlor & ASSOCIATES
 Civil Engineering • Surveying • Landscaping • Construction Services
 49287 West Road
 Wixom, Michigan 48393
 Tel. (248) 437-7803
 Fax. (866) 690-4307
 CONTACT:
 MATTHEW DIFFIN, P.E.

DRAWING ALTERATION
 IT IS A VIOLATION OF LAW FOR ANY PERSON, UNLESS ACTING UNDER THE DIRECTION OF A LICENSED ARCHITECT, PROFESSIONAL ENGINEER, LANDSCAPE ARCHITECT, OR LAND SURVEYOR TO ALTER ANY ITEM ON THIS DOCUMENT IN ANY WAY.

SEAL:

SUN
SUN COMMUNITIES INC.
 27777 FRANKLIN ROAD SUITE 200
 SOUTHFIELD, MICHIGAN 48034
 Phone: (248) 208-2500
 Fax: (248) 208-2640
MR. LEONARD SEMBER
 VICE PRESIDENT
 OF CONSTRUCTION SERVICES

CIDER MILL CROSSINGS
 A PLANNED UNIT HOUSING COMMUNITY
 TYRONETOWNSHIP, LIVINGSTON COUNTY, MI

REVISIONS:

REVISED PER LIVINGSTON COUNTY ROAD COMMISSION 6-31-18 REVIEW
 REVISED PER TWP. PLANNER'S 9-10-18 REVIEW
 REVISED PER TWP. 2-13-19 MEETING COMMENTS
 REVISED PER LARA 5-23-19 REVIEW COMMENTS

SCALE: 1" = 40'
LAYOUT COORD: MAD
PLANNING MGR. MAD
DRAWING BY: MAD
DATE: MAY 29, 2019
JOB NUMBER: 991214

TITLE:
 OLD US-23 \ PRIVATE ROADWAY
 LANDSCAPING \ LIGHTING PLAN

SHEET NUMBER:
 RD-4
 SHEET 4 OF 5

COMMENTS:

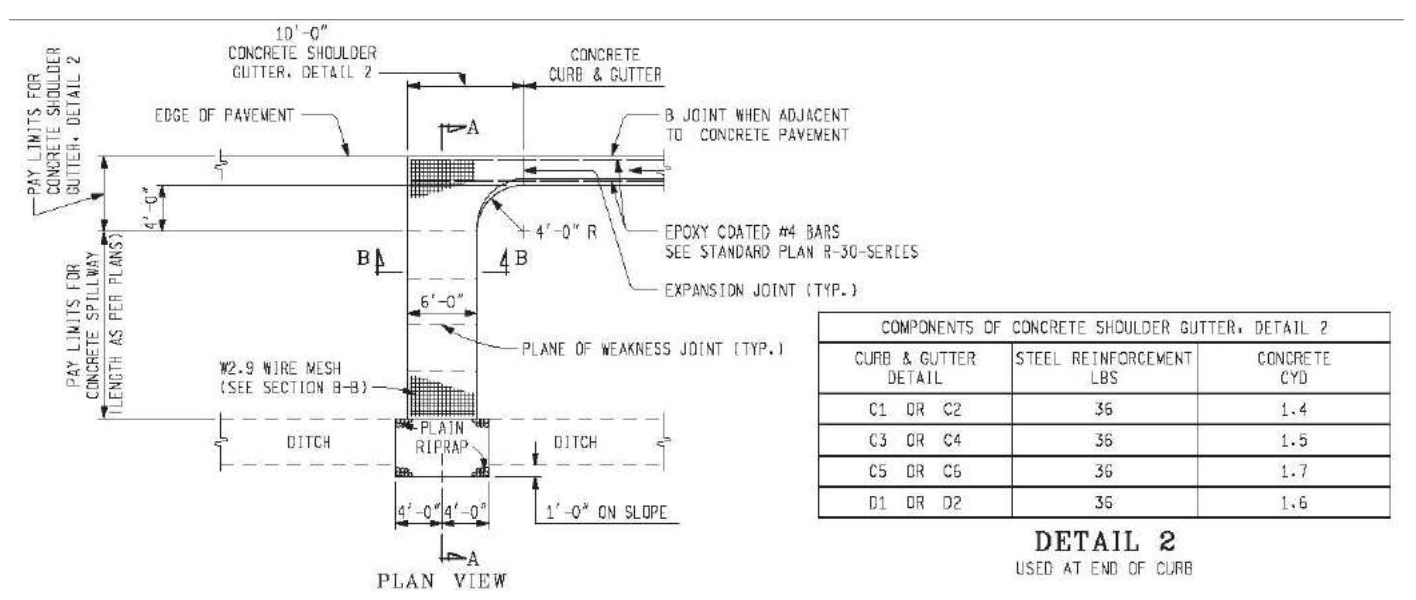

DETAIL	STEEL REINFORCEMENT	CONCRETE	CYD
C1	CR C2	36	1.4
C2	CR C4	36	1.5
C3	CR C5	36	1.7
C4	CR D2	36	1.6

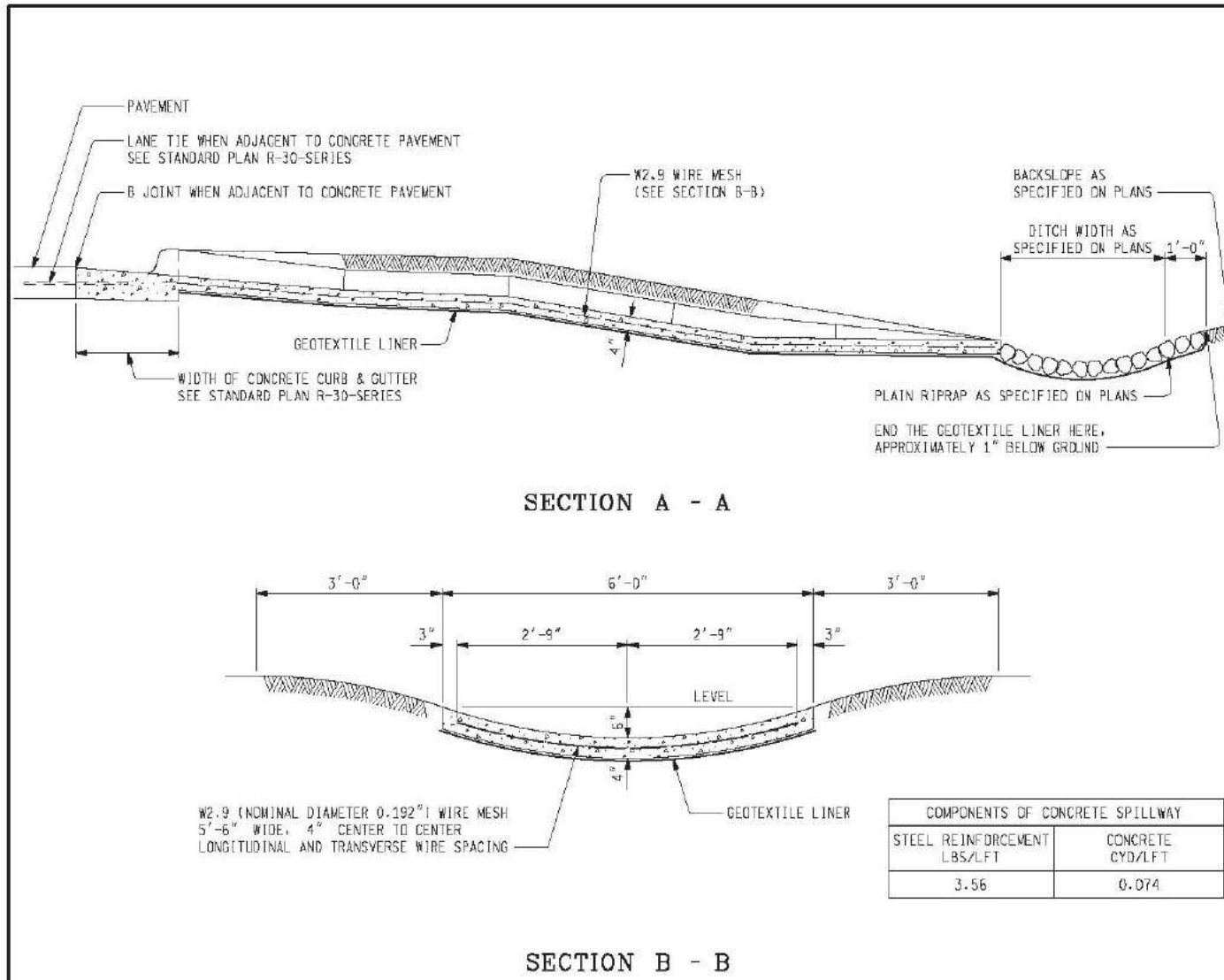

NOTES:
 A GRADUAL UNIFORM TRANSITION SHALL BE MADE FROM THE STANDARD CONCRETE CURB AND GUTTER TO THE CONCRETE SPILLWAY.
 PLANE OF WEAKNESS JOINT SPACING SHALL BE AT UNIFORM INTERVALS OF APPROXIMATELY 4'-0".
 THE SPILLWAY SHOULDERS AND FORESLOPES WILL BE UNDERLAIN WITH GEOTEXTILE LINER FROM THE BACK SIDE OF CURB TO THE FAR END OF THE PLAIN RIPRAP INCLUDING THE ENTIRE FOOTPRINT OF THE PLAIN RIPRAP.
 WHEN USING SPILLWAYS IN OTHER AREAS, SUCH AS BACKSLOPES, THE GEOTEXTILE LINER SHALL UNDERLAY THE FULL LENGTH OF THE SPILLWAY AND THE ENTIRE FOOTPRINT OF THE PLAIN RIPRAP. THE GEOTEXTILE LINER SHALL HAVE A MINIMUM WIDTH EQUAL TO THE WIDTH OF THE SPILLWAY.
 THE SPILLWAY SHALL BE GIVEN A TRANSVERSE CONCRETE BROOM FINISH.
 WHILE CONCRETE SPILLWAY IS SHOWN ON THE FORESLOPE, IT MAY BE USED ON THE BACKSLOPE, AS SPECIFIED ON THE PLANS. CONCRETE SHOULDER GUTTERS SHOULD BE CORRESPONDINGLY DOTTED.
 THE CURB AND GUTTER SHALL BE ALIGNED WITH THE BEAM BARRIERS AS SPECIFIED ON STANDARD PLAN R-67-SERIES. THE LOCATION OF BARRIERS SHOULD BE DETERMINED PRIOR TO LOCATING THE SPILLWAY OR OVERSPREAD HEADS.

MICHIGAN DEPARTMENT OF TRANSPORTATION
 BUREAU OF DEVELOPMENT STANDARD PLAN FOR
CONCRETE SHOULDER GUTTER AND SPILLWAY

7-30-07	10-29-2016	R-35-D	SHEET 2 OF 2
LUCKA, WPH/ML	PJL/ML		

PROVIDE DETAIL 'M' OPENING WHERE NECESSARY TO PROVIDE POSITIVE ACROSS INTERSECTIONS TO NEAREST DRAINAGE BASINS OR AS NOTED ON PLANS.

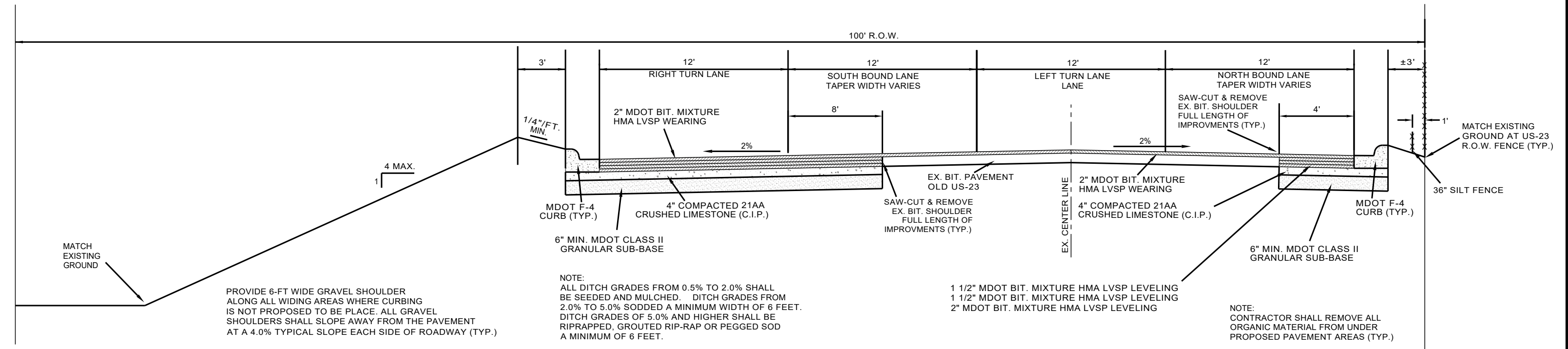
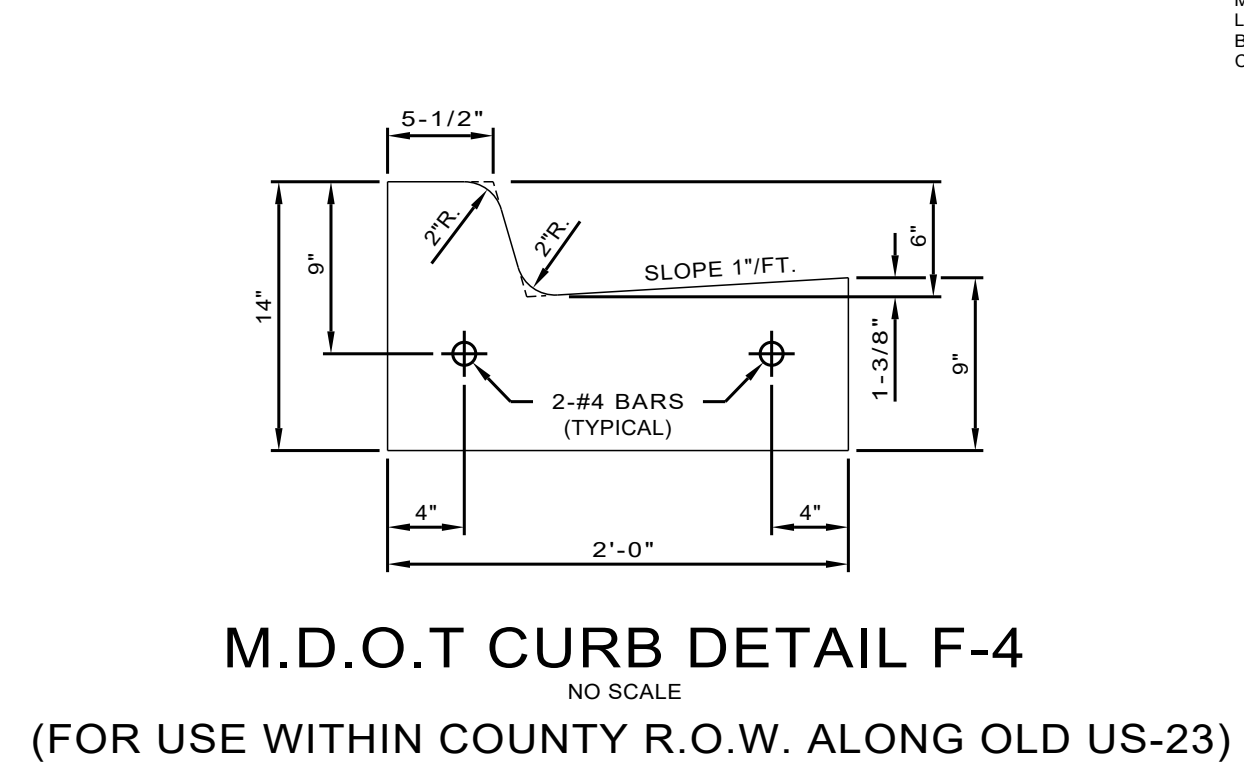
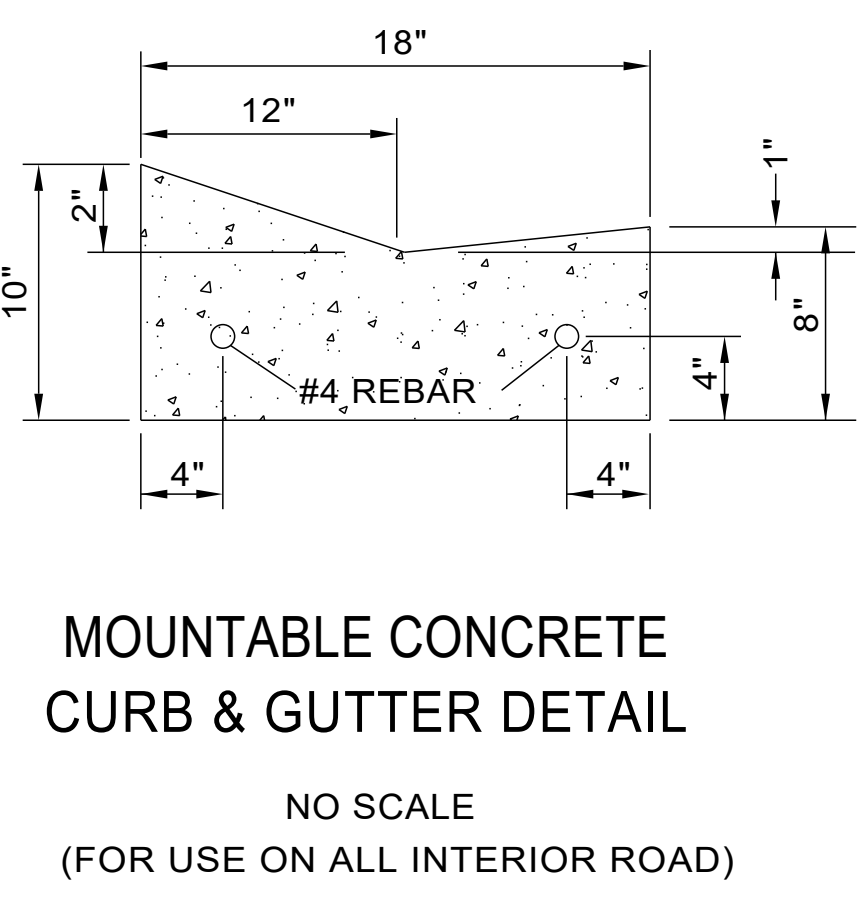
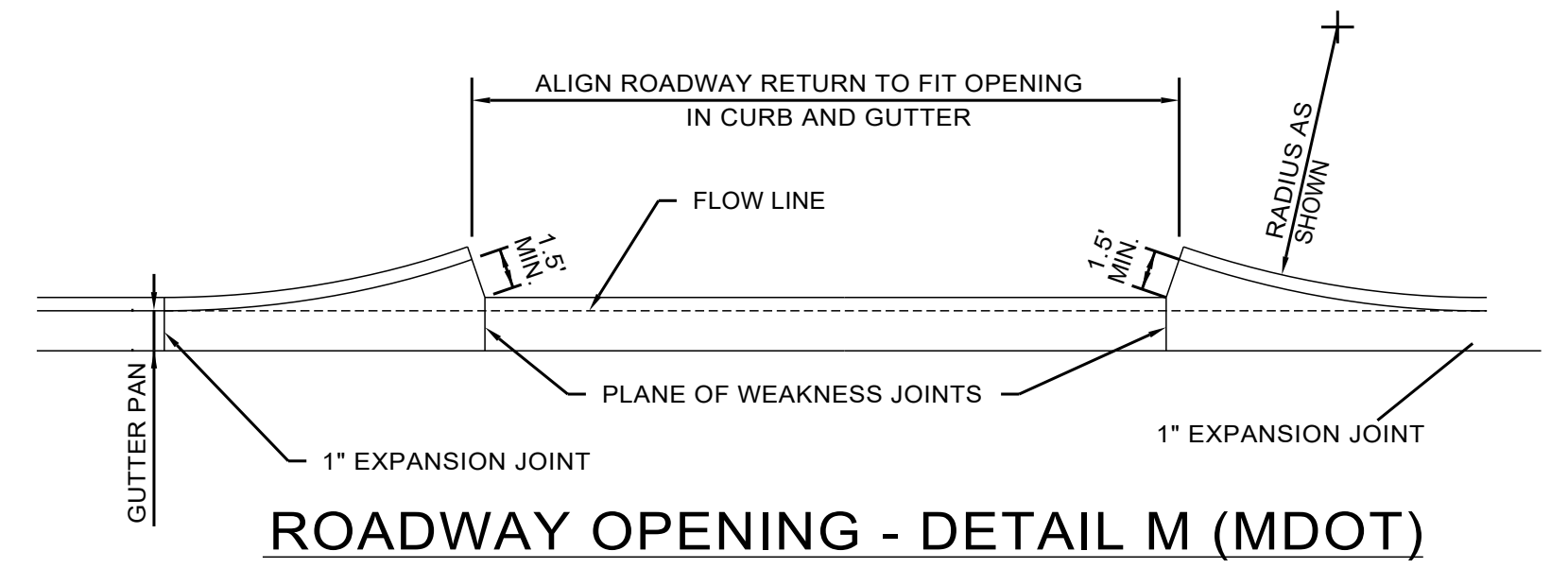

TYPICAL OLD US-23 ROAD WIDENING CROSS SECTION VIEWING NORTH

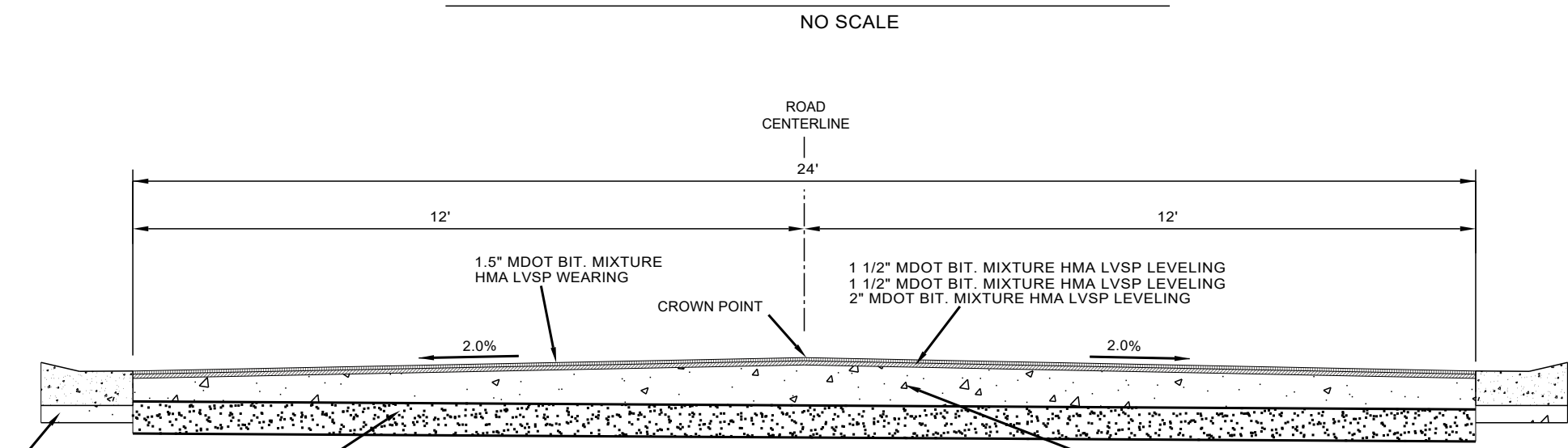

PRIVATE ROADWAY CROSS-SECTION

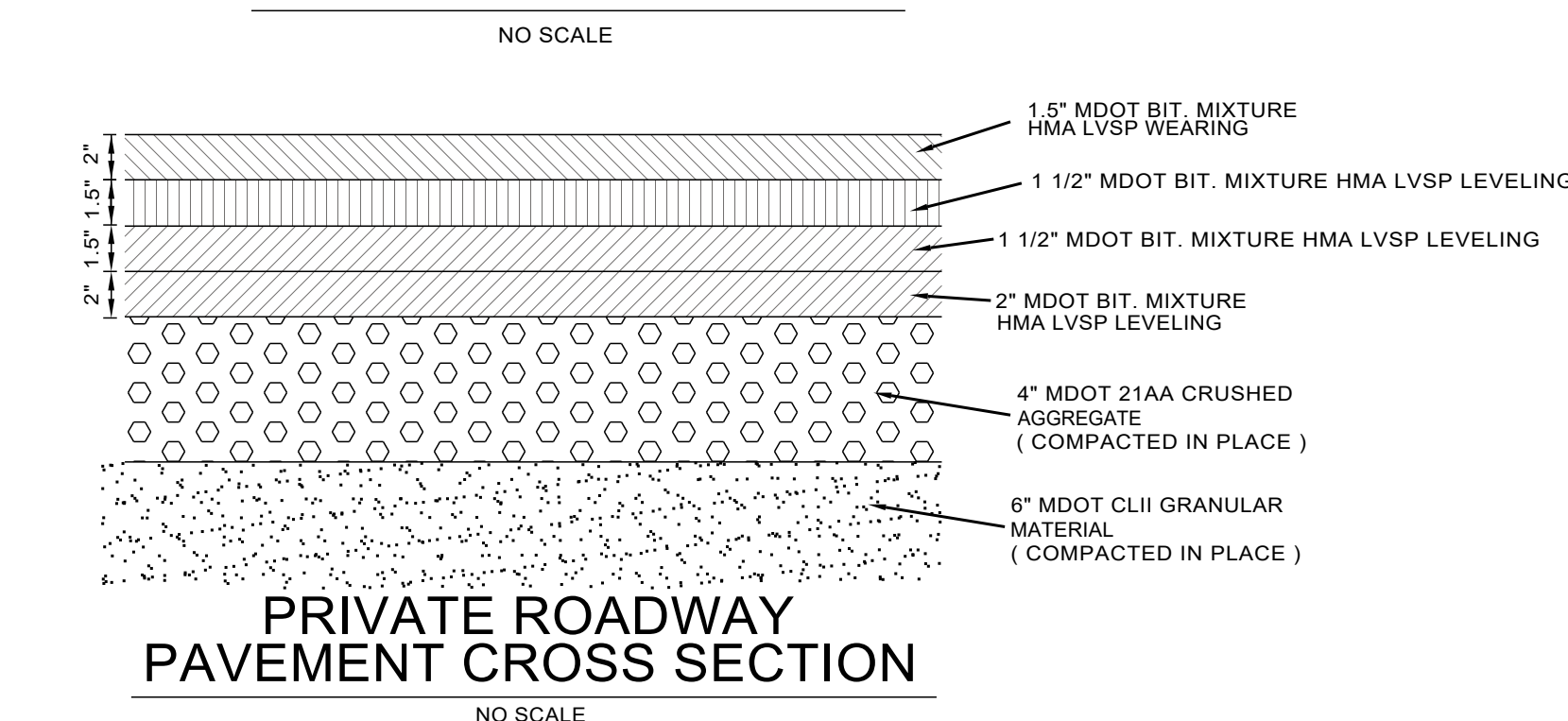

PRIVATE ROADWAY PAVEMENT CROSS SECTION

CONSULTANT:
Diffin-Umlor & ASSOCIATES
 Civil Engineering • Surveying • Landscaping • Construction Services
 49287 West Road
 Wixom, Michigan 48393
 Tel. (248) 437-7803
 Fax. (866) 690-4307
 CONTACT:
 MATTHEW DIFFIN, P.E.

DRAWING ALTERATION
 IT IS A VIOLATION OF LAW FOR ANY PERSON, UNLESS ACTING UNDER THE DIRECTION OF A LICENSED ARCHITECT, PROFESSIONAL ENGINEER, LANDSCAPE ARCHITECT, OR LAND SURVEYOR TO ALTER ANY ITEM ON THIS DOCUMENT IN ANY WAY.
 ANY LICENSEE WHO ALTERS THIS DOCUMENT IS REQUIRED BY LAW TO AFFIX HIS OR HER SEAL AND THE NOTATION "ALTERED BY" FOLLOWED BY HIS OR HER SIGNATURE AND SPECIFIC DESCRIPTION OF THE ALTERATIONS.

SEAL:

SUN
SUN COMMUNITIES INC.
 2777 FRANKLIN ROAD SUITE 200
 SOUTHFIELD, MICHIGAN 48034
 Phone: (248) 208-2500
 Fax: (248) 208-2640
MR. LEONARD SHEMBER
 VICE PRESIDENT
 OF CONSTRUCTION SERVICES
CIDER MILL CROSSINGS
 A PLANNED UNIT HOUSING COMMUNITY
 TYRONETOWNSHIP, LIVINGSTON COUNTY, MI

REVISIONS:
 REVISED PER LIVINGSTON COUNTY ROAD COMMISSION 6-31-18 REVIEW
 REVISED PER TWP. PLANNER'S 9-10-18 REVIEW
 REVISED PER LARA 5-23-19 REVIEW
 COMMENTS

SCALE: 1" = 60'
 LAYOUT COORD: MAD
 PLANNING MGR: MAD
 DRAWING BY: MAD
 DATE: MAY 29, 2019
 JOB NUMBER: 991214
 TITLE: ROADWAY DETAILS
 SHEET NUMBER: RD-5
 SHEETS 5 OF 5
 COMMENTS: